

## CENTRALAB SPECIAL APPLICATION CERAMIC CAPACITORS

# 5 KVDC Thru 20 KVDC RF RATED TRANSMITTING

### 850-SERIES

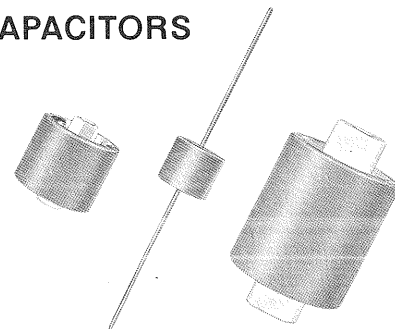

### Specifications

**CAPACITANCE RANGE:** 3pf to .001mf. Tested at 0.5 to 5.0 volts RMS, listed Test Freq. and +25°C.

**CAPACITANCE TOLERANCE:** ±10% or ±20% as listed.

**WORKING VOLTAGE:** 5000, 7500, 15,000 or 20,000 volts DC as listed.

**DISSIPATION FACTOR (D.F.):** 0.1% to 1.5% maximum as listed. Tested at 0.5 to 5.0 volts RMS, listed Test Freq. and +25°C.

**DIELECTRIC STRENGTH:** 150% of rated Working Voltage.

**INSULATION RESISTANCE:** 10,000 megohms minimum. Tested at 1000 volts DC maximum.

**TEMPERATURE COEFFICIENT OR CHARACTERISTIC:** NPO, N750, N3300 or EIA code X5T, X5U as listed.

**OPERATING TEMPERATURE RANGE:** -55°C. to +85°C.

**HUMIDITY PROTECTION:** Silicone coated.

**LEADS:** Tinned Wire.

**TERMINALS:** Silver plated.

**MARKING:** CRL<sup>®</sup>, catalog number, capacitance value, capacitance tolerance, working voltage and temperature coefficient or EIA temperature characteristic code.

Centralab RF Rated, ceramic transmitting capacitors are designed primarily for use in applications where very high RF currents, high KVA ratings and high working voltages exist. Special capacitor design reduces terminal self-inductance to permit higher frequency operation. A humidity resistant silicone coating and long flashover path assures safe, high voltage operation in free air. Units also feature stable temperature-capacitance characteristics and rugged mechanical construction for maximum reliability.

The 850-Series capacitors are extensively used in transmitters, antennas, induction heaters, X-ray, diathermy and electronic welding equipment.

CAP.	CATALOG NUMBER	CAP. TOL.	VOLTAGE DCW PLUS HF PEAK	TEMP. COEF./EIA CODE	MAX. D.F.	TEST FREQ.
------	----------------	-----------	--------------------------	----------------------	-----------	------------

### 853, 854, 855 — Series Wire Leads

3 pf	855-3Z	± 10%	5,000	NPO	0.217%	1 MHz
5	855-5Z	± 10%	5,000	NPO	0.200%	1 MHz
10	855-10N	± 10%	5,000	N750	0.167%	1 MHz
10	854-10Z	± 10%	5,000	NPO	0.167%	1 MHz
20	854-20N	± 10%	5,000	N750	0.120%	1 MHz
20	853-20Z	± 10%	5,000	NPO	0.120%	1 MHz
40	853-40N	± 10%	5,000	N750	0.100%	1 MHz

### 853A, 854A, 855A — Series Threaded Terminals

3 pf	855A-3Z	± 10%	5,000	NPO	0.217%	1 MHz
5	855A-5Z	± 10%	5,000	NPO	0.200%	1 MHz
10	855A-10N	± 10%	5,000	N750	0.167%	1 MHz
10	854A-10Z	± 10%	5,000	NPO	0.167%	1 MHz
20	854A-20N	± 10%	5,000	N750	0.120%	1 MHz
20	853A-20Z	± 10%	5,000	NPO	0.120%	1 MHz
40	853A-40N	± 10%	5,000	N750	0.100%	1 MHz

### 850S, 858S — Series Threaded Terminals

25 pf	850S-25Z	± 10%	7,500	NPO	0.1%	1 MHz
50	850S-50Z	± 10%	7,500	NPO	0.1%	1 MHz
50	850S-50N	± 10%	7,500	N750	0.1%	1 MHz
75	850S-75N	± 10%	7,500	N750	0.1%	1 MHz
100	850S-100N	± 10%	5,000	N750	0.1%	1 MHz
500	858S-500	± 20%	5,000	X5T	1.5%	1 kHz
.001 mf	858S-1000	± 20%	5,000	X5U	1.5%	1 kHz

### 857 — Series Threaded Terminals

25 pf	857-25Z	± 10%	15,000	NPO	0.1%	1 MHz
50	857-50Z	± 10%	15,000	NPO	0.1%	1 MHz
100	857-100N	± 10%	15,000	N750	0.1%	1 MHz
200	857-200N	± 10%	7,500	N750	0.1%	1 MHz

### 859S — Series Threaded Terminals

50 pf	859S-50Z	± 10%	20,000	NPO	0.1%	1 MHz
100	859S-100Z	± 10%	20,000	NPO	0.1%	1 MHz
250	859S-250N	± 10%	20,000	N750	0.1%	1 MHz
500	859S-500N	± 10%	15,000	N3300	0.2%	1 MHz

# TYPICAL RF CHARACTERISTICS

Data is based on not exceeding the maximum rated voltage ("\*" readings) or a 30°C maximum rise above a 25°C ambient in still air.

Reactive power ratings (KVAR) are calculated from voltage limited currents.

For operation in an air stream, multiply the R.F. MAX. AMPS by specific Fan Factor to obtain allowable higher current rating. Rated Working Voltage must not be exceeded.

CATALOG NUMBER	1 MHz			10 MHz			30 MHz			FAN FACTORS			
	R.F. MAX. AMPS	KVAR	Q TYP.	R.F. MAX. AMPS	KVAR	Q TYP.	R.F. MAX. AMPS	KVAR	Q TYP.	FEET PER MINUTE			
										50	100	250	650
855-3Z	0.066*	0.23	2,000	0.66*	2.3	5,000	1.4	3.2	5,000	1.15	1.3	1.7	2.6
855-5Z	0.11*	0.38	5,000	1.1*	3.8	5,000	1.6	2.8	2,000	1.15	1.3	1.7	2.6
855-10N	0.22*	0.78	10,000	1.7	4.2	10,000	2.3	2.9	7,500	1.15	1.3	1.7	2.6
854-10Z	0.22*	0.78	10,000	1.8	5.4	10,000	2.1	2.3	7,500	1.1	1.2	1.4	1.8
854-20N	0.44*	1.55	7,000	3.1	7.5	12,000	3.4	3.0	15,000	1.1	1.2	1.4	1.8
853-20Z	0.44*	1.5	9,000	2.7	5.6	4,500	2.8	2.0	4,300	1.1	1.2	1.4	1.8
853-40N	0.89*	3.1	15,000	4.4	7.7	15,000	3.5	1.7	3,500	1.1	1.2	1.4	1.8
855A-3Z	0.066*	0.23	2,000	0.66*	2.3	5,000	1.4	3.2	5,000	1.15	1.3	1.7	2.6
855A-5Z	0.11*	0.38	5,000	1.1*	3.8	5,000	1.6	2.8	2,000	1.15	1.3	1.7	2.6
855A-10N	0.22*	0.78	10,000	1.7	4.2	10,000	2.3	2.9	7,500	1.15	1.3	1.7	2.6
854A-10Z	0.22*	0.78	10,000	1.8	5.4	10,000	2.1	2.3	7,500	1.1	1.2	1.4	1.8
854A-20N	0.44*	1.55	7,000	3.1	7.5	12,000	3.4	3.0	15,000	1.1	1.2	1.4	1.8
853A-20Z	0.44*	1.5	9,000	2.7	5.6	4,500	2.8	2.0	4,300	1.1	1.2	1.4	1.8
853A-40N	0.89*	3.1	15,000	4.4	7.7	15,000	3.5	1.7	3,500	1.1	1.2	1.4	1.8
850S-25Z	0.84*	4.4	4,300	3.1	6.1	4,000	5.6	6.6	4,800	1.1	1.3	1.6	2.4
850S-50Z	1.7*	8.9	7,000	4.2	5.6	4,200	7.6	6.0	3,000	1.1	1.25	1.6	2.3
850S-50N	1.7*	8.9	7,000	5.0	7.9	7,600	8.5	7.7	4,000	1.1	1.25	1.6	2.3
850S-75N	2.5*	13.2	14,000	6.2	8.1	5,500	9.0	5.6	3,700	1.1	1.25	1.6	2.3
850S-100N	3.4	19.0	15,000	7.3	8.7	9,000	9.2	4.6	2,000	1.1	1.25	1.6	2.3
858S-500	1.1	0.39	300	2.5	0.21	120	3.0	0.1	55	1.1	1.2	1.4	2.0
858S-1000	1.4	0.3	200	3.1	0.15	—	3.7	0.076	—	1.1	1.2	1.4	2.0
857-25Z	1.7*	18.5	5,000	6.2	22.0	4,000	6.7	8.6	8,000	1.15	1.3	1.6	1.9
857-50Z	3.3*	35.4	4,000	7.4	18.0	4,500	8.1	7.1	3,000	1.15	1.3	1.6	1.9
857-100N	4.6	35.0	6,500	12.0	22.0	6,500	15.0	11.1	4,000	1.15	1.3	1.6	1.9
857-200N	5.1	23.0	5,000	8.5	6.2	4,000	15.0	6.0	2,000	1.15	1.3	1.6	1.9
859S-50Z	3.1	31.5	5,000	10.4	36.0	6,200	16.2	28.8	5,000	1.15	1.3	1.7	2.3
859S-100Z	3.8	23.5	4,500	12.9	27.4	4,500	19.4	20.6	3,000	1.15	1.3	1.7	2.3
859S-250N	9.2	52.0	5,000	13.0	11.0	3,000	35.0	25.0	1,000	1.15	1.3	1.7	2.3
859S-500N	6.7	14.0	3,800	14.0	5.9	800	23.0	5.4	—	1.15	1.3	1.7	2.3

853-854-855 - SERIES

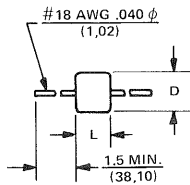

SERIES	LENGTH		DIA.	
	in. ± .031	mm ± 0,78	in. ± .031	mm ± 0,78
853	.437	11,09	.500	12,70
854	.375	9,52	.375	9,52
855	.343	8,71	.250	6,35

853A-854A-855A - SERIES

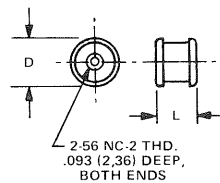

SERIES	LENGTH		DIA.	
	in. ± .031	mm ± 0,78	in. ± .031	mm ± 0,78
853A	.484	12,29	.562	14,27
854A	.422	10,71	.437	11,09
855A	.390	9,90	.312	7,92

850S-858S - SERIES

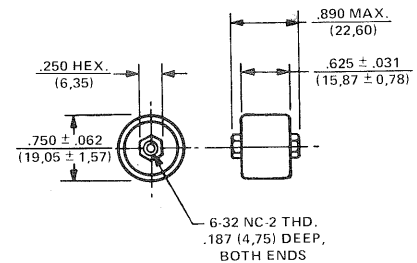

857 - SERIES

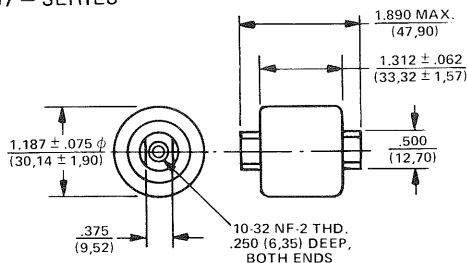

859S - SERIES

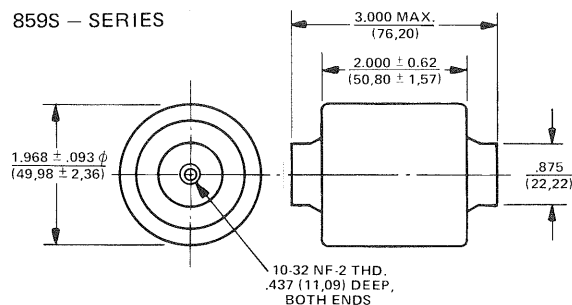

INCH (MILLIMETER)      INCH (MILLIMETER)