

FILE NO.	JPM405A-R2
PART NO.	-

REVISIONS				
REV.	DESCRIPTION	DATE	ECO No.	APP'VD
A	RELEASE TO PRODUCT	2010/11/04		CHANG

NOTE:  
 1.MATERIAL : SPCC t=1.5mm=0.059in=16ga.  
 2.FINISH : POWDER COATING.  
 3.COLOR : BLACK.  
 4.SIZE :  
 130x27.4x29.3 mm.  
 5.12x1.08x1.15 in.  
 5.WEIGHT :  
 0.065kg  
 0.143lb.  
 6.ADAPTER SPEC:  
 DUPLEX SC ADAPTER PhBr X 3pcs  
 INSERTION LOSS: S.M. 0.20dB/0.30dB (TYP./MAX.)  
 M.M. 0.30dB/0.50dB (TYP./MAX.)  
 RETENTION FORCE IS 200GF(1.96N)~600GF(5.88N).  
 7.BLACK BOX P/N: JPM405A-R2

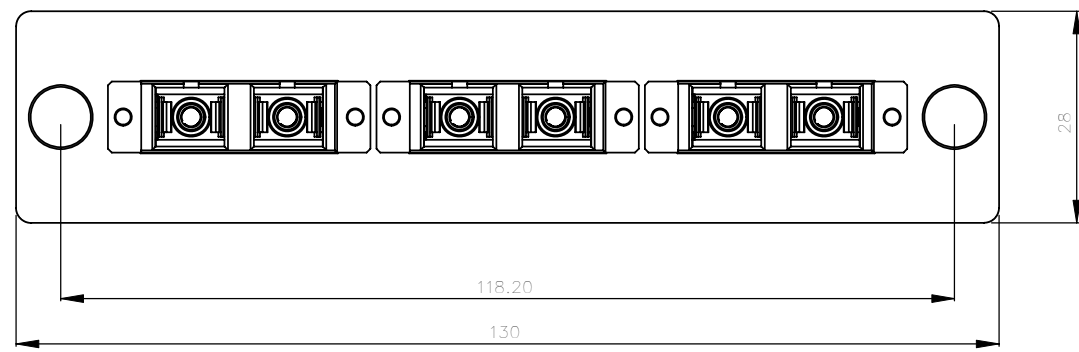
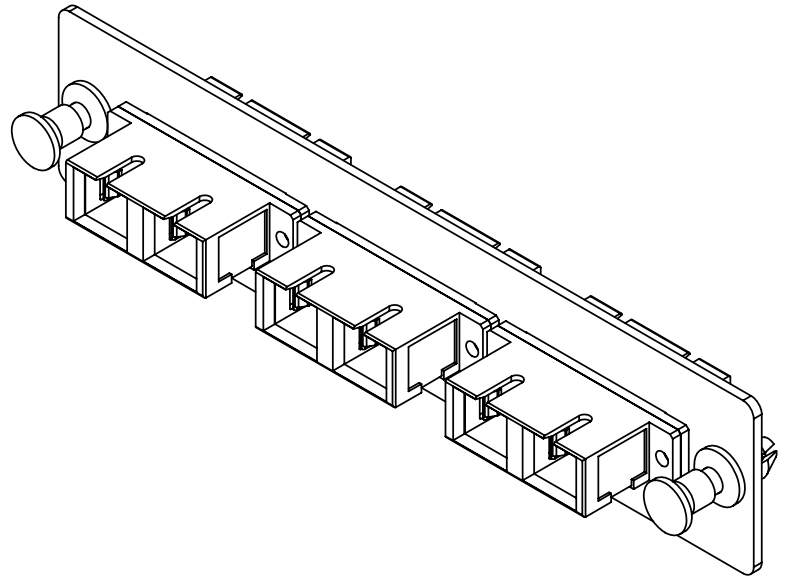

MATERIAL		SIGNATURE	DATE	Another quality product from <b>BLACK BOX</b> <small>724-746-5100 • www.blackbox.com</small>	
QUANTITY		DRAWN	LU	2010/11/04	DWG. NAME <b>PANEL WITH DUPLEX SC ADAPTER</b> SIZE DWG. NO. REV. <b>C JPM405A-R2 A</b> SCALE : N/A 2010/11/04 SHEET 1 OF 1
		PROJECT ENGINEER	LIU	2010/11/04	
		CHECKED	LIU	2010/11/04	
		APPROVED	CHANG	2010/11/04	
		DRAWING MANAGER	CHUNG	2010/11/04	