

SERIES 38C Miniature Pushbutton Switches

FEATURES

- SPDT and DPDT Circuitry
- Choice of Bushings, and Terminations
- Caps and Frames Available
- UL Recognized



DIMENSIONS IN INCHES (AND MILLIMETERS)

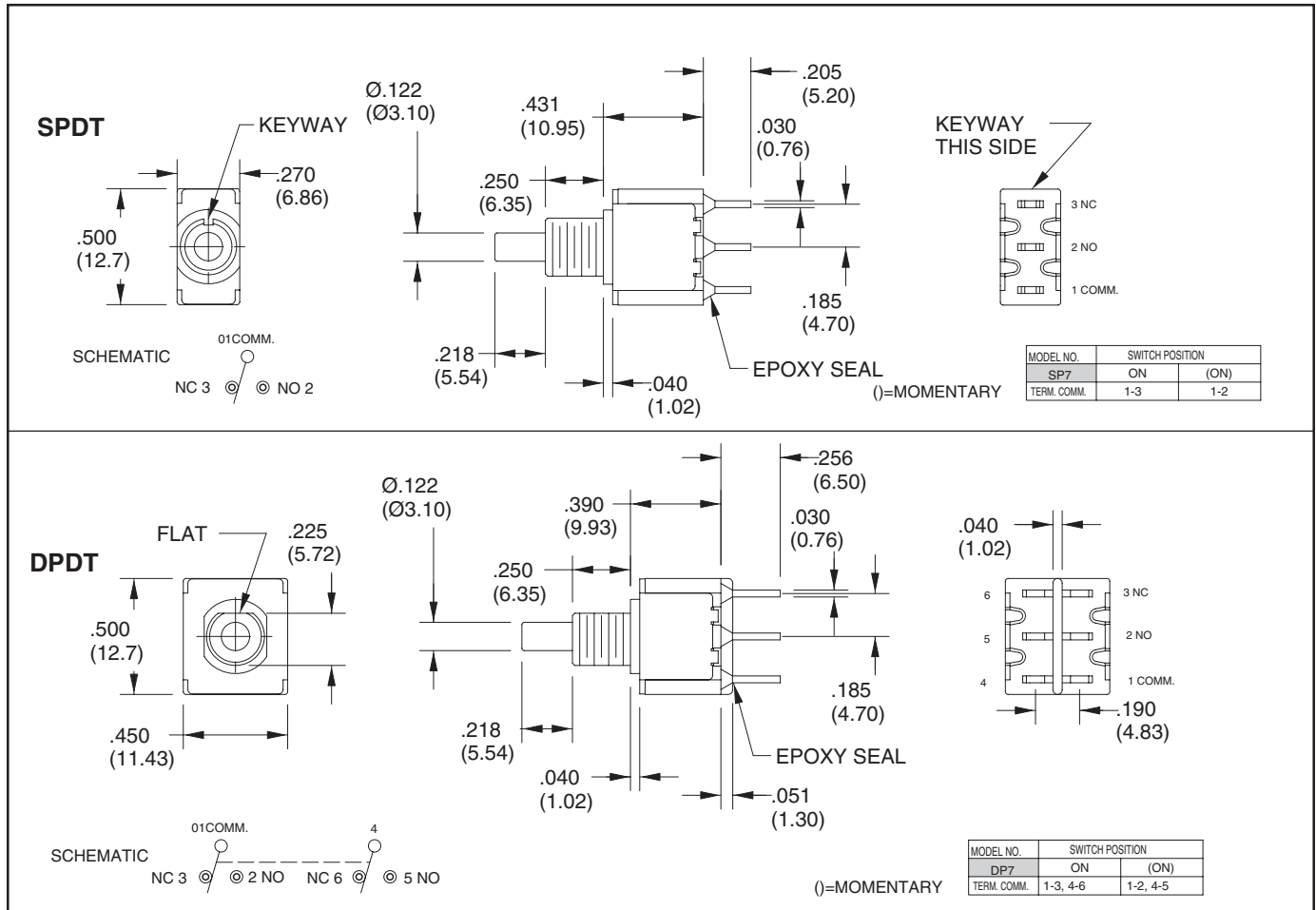

BUSHING OPTIONS IN INCHES (AND MILLIMETERS)

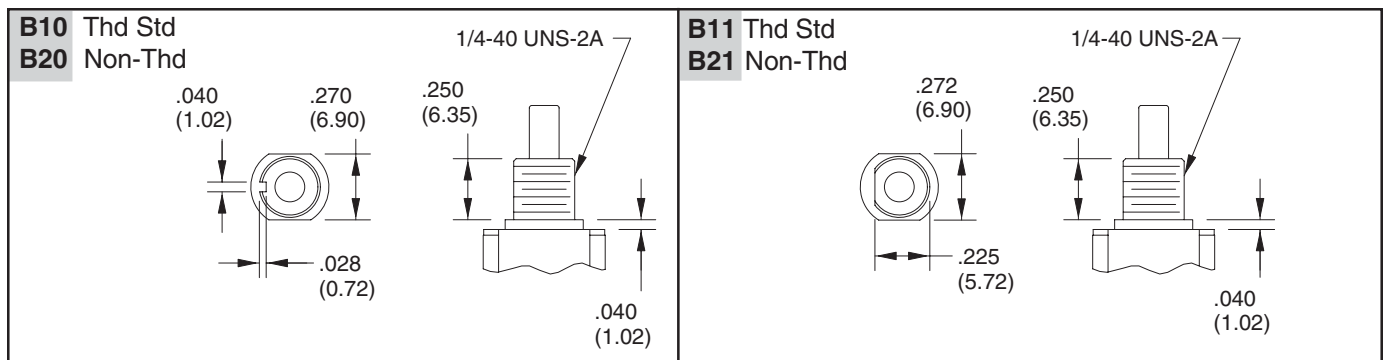

TERMINATION OPTIONS IN INCHES (AND MILLIMETERS)

<p>M1 Solder Lug (Std)</p> <p>THK. .030 (0.76)</p>	<p>M2 P. C. Mount</p> <p>THK. .030 (0.76)</p>	<p>M3 P. C. Mount, Quick Connect</p> <p>.030 (0.76) THK.</p>	<p>WX Wire Wrap</p> <table border="1"> <thead> <tr> <th>OPTION CODE</th> <th>DIM. "A"</th> </tr> </thead> <tbody> <tr> <td>W1</td> <td>.750(19.05)</td> </tr> <tr> <td>W2</td> <td>.964(24.48)</td> </tr> <tr> <td>W3</td> <td>.425(10.80)</td> </tr> <tr> <td>W4</td> <td>1.062(26.97)</td> </tr> </tbody> </table>	OPTION CODE	DIM. "A"	W1	.750(19.05)	W2	.964(24.48)	W3	.425(10.80)	W4	1.062(26.97)
OPTION CODE	DIM. "A"												
W1	.750(19.05)												
W2	.964(24.48)												
W3	.425(10.80)												
W4	1.062(26.97)												
<p>M6 Right Angle P. C. Mount, Horizontal</p> <p>SPDT</p> <p>DPDT</p> <p>P.C. MOUNTING</p>													
<p>M7 Right Angle P.C. Mount, Vertical</p> <p>SPDT</p> <p>P.C. MOUNTING</p>													

Pushbutton Switches

TERMINATION OPTIONS (CONT.) IN INCHES (AND MILLIMETERS)

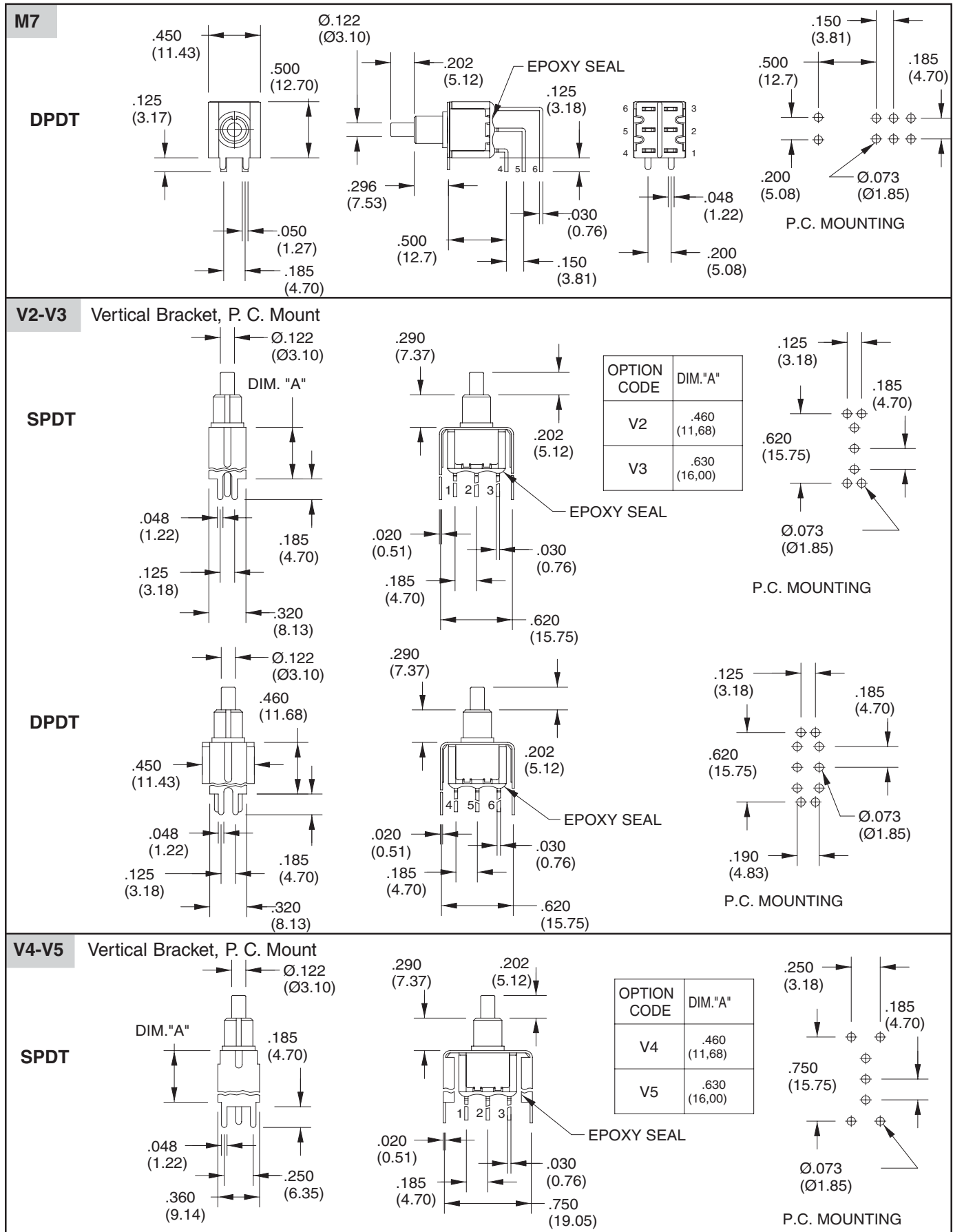

TERMINATION OPTIONS (CONT.) IN INCHES (AND MILLIMETERS)

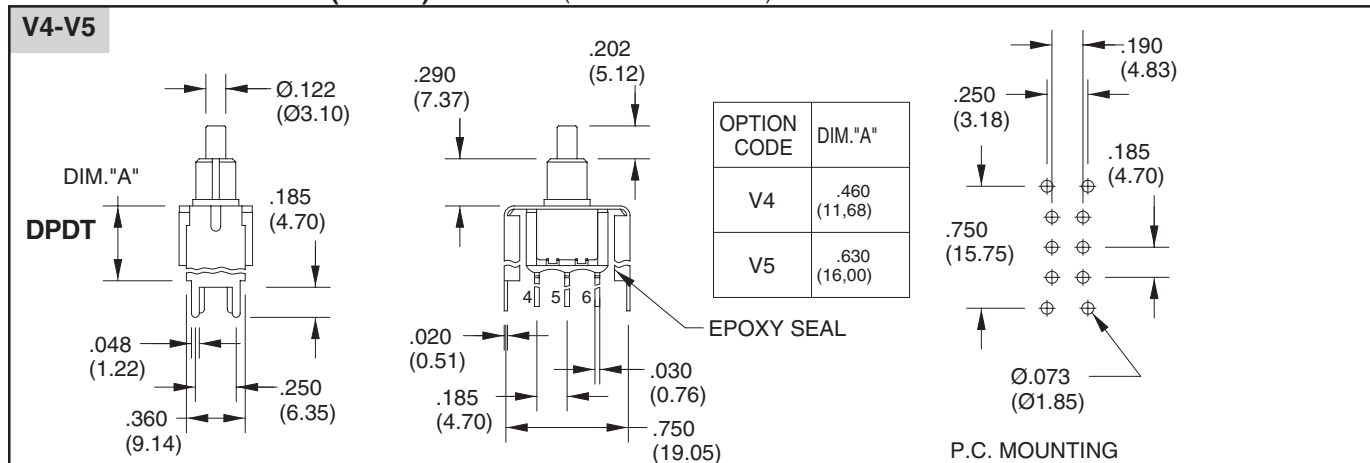

Snap-in Termination Options

(Snap-in termination options have the same PC layout as M2, M6 and M7 options)

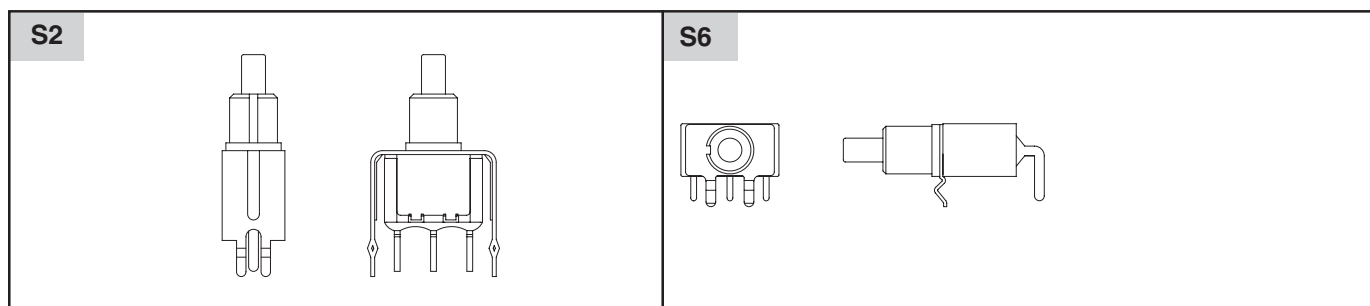

BUSHING OPTIONS IN INCHES (AND MILLIMETERS)
FOR PANEL MOUNTING

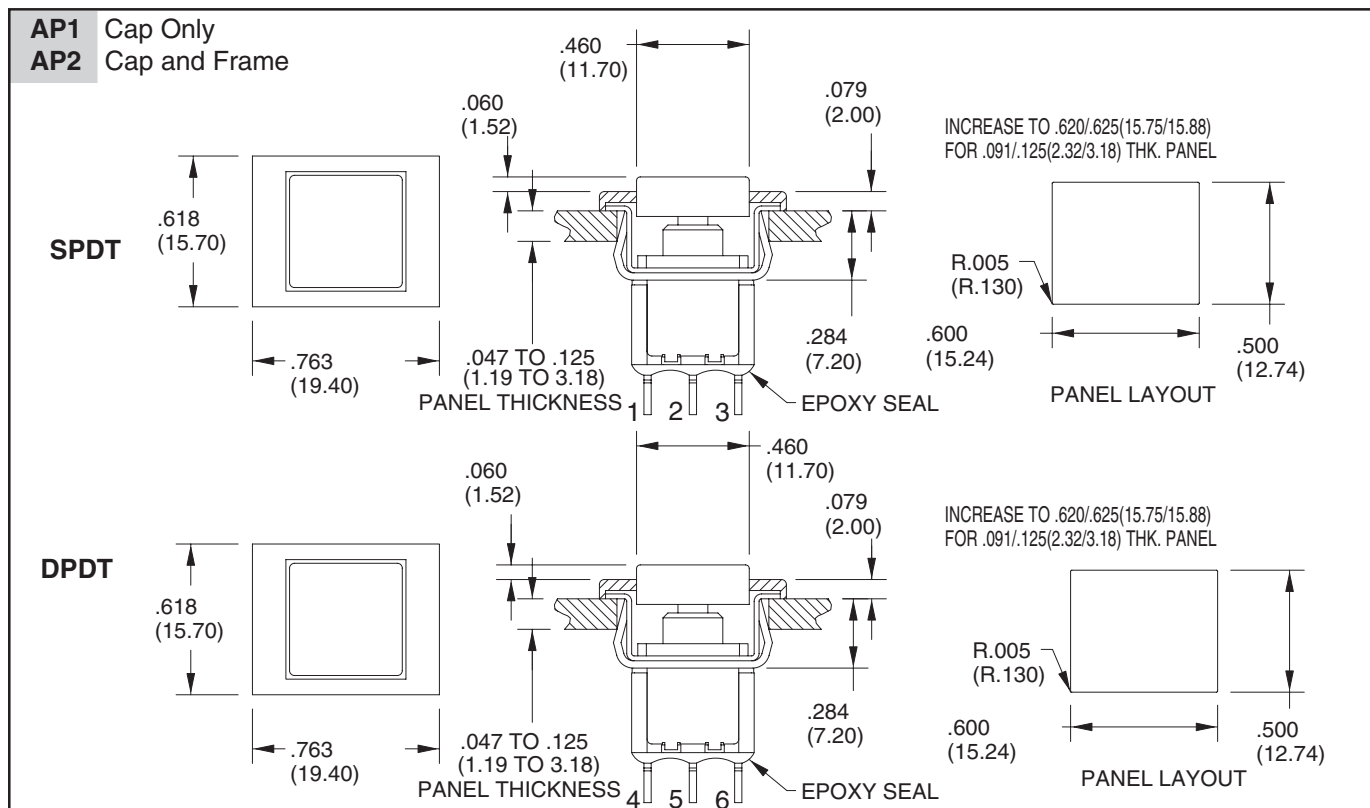

BUSHING OPTIONS IN INCHES (AND MILLIMETERS) FOR PANEL MOUNTING

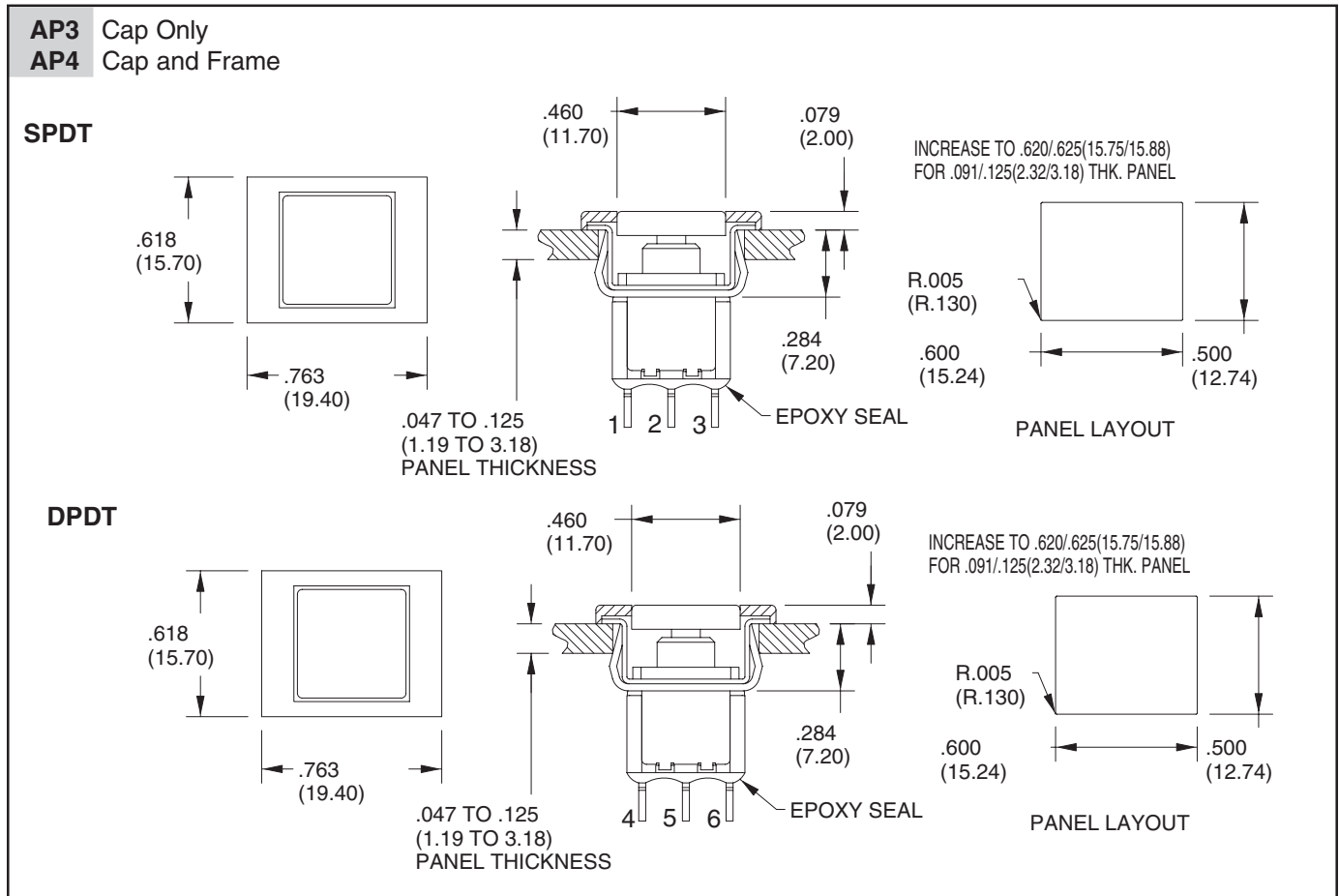

SPECIFICATIONS

RATINGS

Contact Rating: Q & G option - 3A with resistive load @ 125 VAC or 28 VDC; 1.5A with resistive load @ 250 VAC. R option - 0.4 VA max @ 20 Vmax (AC or DC)

Electrical Life: 50,000 make-and-break cycles at full load

Travel: .050 ± .010

Contact Resistance: 20 milliohms max. initial @ 2-4 VDC, 100 mA

Insulation Resistance: 1,000 megaohms minimum

Dielectric Strength: 1,000 V RMS @ sea level

Operating Temperature: -30°C to 85°C

MATERIALS

Case: Diallyl phthalate (DAP) (UL94V-0)

Plunger: Glass filled nylon or glass filled polyester

Bushing: Brass, nickel plated

Housing: Stainless steel

Terminal/Switch Support: Brass, electroplated

Terminal Seal: Epoxy

ORDERING INFORMATION

SERIES	MODEL NO.	PLUNGER	BUSHING	TERMINATION	CONTACT	SEAL
38C	SP7		B10	M1	Q	T
38C = Miniature Pushbutton Switches	Options: SP7, DP7 (see models for switching positions)	Options: Blank=std as shown in dwg 0 = 0.0 (Flush) 1 = .205 (5.02) 2 = .079 (2.00)	Options: AP1, AP2, AP3, AP4, B10, B11, B21, B21 (see bushing options)	Options: M1, M2, M3, M6, M7, S2, S6, V2, V3, V4, V5, W1, W2, W3, W4 (see termination options)	R = Copper alloy, gold plate over nickel plate. Q = Copper alloy, silver plated G=Gold plate over silver plate	T = Lead Free and RoHS Compliant