

## FEATURES

- 20 $\mu$ A to 20mA Operating Range
- Guaranteed 1% Initial Voltage Tolerance
- Guaranteed 1 $\Omega$  Dynamic Impedance
- Very Low Power Consumption

## APPLICATIONS

- Portable Meter References
- Portable Test Instruments
- Battery-Operated Systems
- Panel Meters
- Current Loop Instrumentation

## DESCRIPTION

The LM185-2.5 is a two-terminal band gap reference diode that has been designed for applications which require precision performance with micropower operation. The device provides guaranteed operation specifications at currents as low as 20 $\mu$ A. The nominal voltage is 2.5V with both 1% and 2% tolerances available. Some additional features are: maximum dynamic impedance of 1 $\Omega$ , low noise and excellent stability over time and temperature. The advanced design, processing and testing techniques make Linear's LM185-2.5 a superior choice over previous designs. A circuit for cold junction compensation of a thermocouple is shown below.

For applications requiring guaranteed temperature drift, see the LT1034 data sheet.

## TYPICAL APPLICATION

Thermocouple Cold Junction Compensator

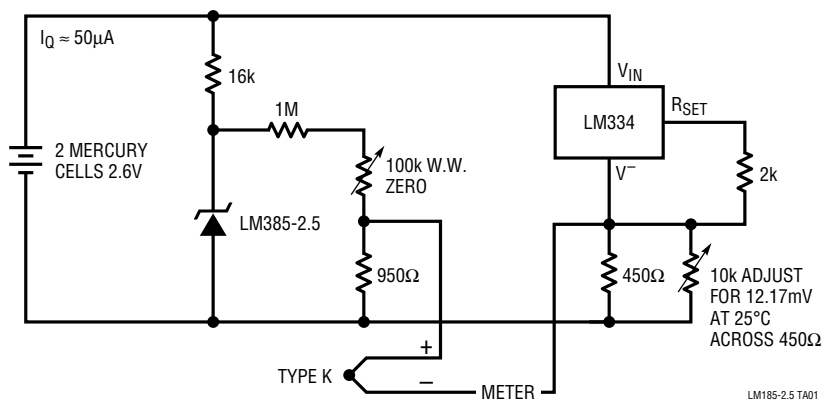

LM185-2.5 TA01

Reverse Voltage Change

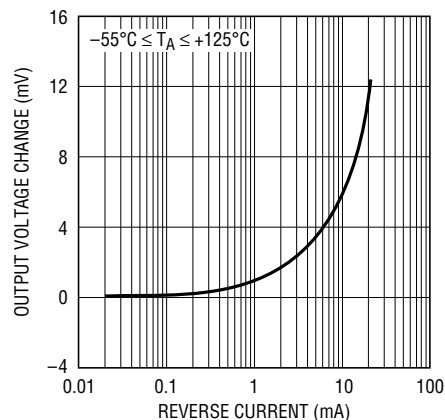

LM185-2.5 TA02

# LM185-2.5/ LM285-2.5/LM385-2.5

## ABSOLUTE MAXIMUM RATINGS

Reverse Breakdown Current .....	30mA	Storage Temperature Range	
Forward Current.....	10mA	LM185-2.5 .....	-65°C to 150°C
Operating Temperature Range		LM285-2.5 .....	-65°C to 150°C
LM185-2.5 .....	-55°C to 125°C	LM385-2.5 .....	-65°C to 150°C
LM285-2.5 .....	-40°C to 85°C	Lead Temperature (Soldering, 10 sec.).....	300°C
LM385-2.5 .....	0°C to 70°C		

## PACKAGE/ORDER INFORMATION

TOP VIEW	ORDER PART NUMBER	BOTTOM VIEW	ORDER PART NUMBER	BOTTOM VIEW	ORDER PART NUMBER
<p>S8 PACKAGE 8-LEAD PLASTIC SO LM185-2.5 P003</p>	LM285S8-2.5	<p>H PACKAGE 2-LEAD TO-46 METAL CAN LM185-2.5 P001</p>	LM185H-2.5	<p>Z PACKAGE 3-LEAD TO-92 PLASTIC LM185-2.5 P002</p>	LM285Z-2.5
	LM385S8-2.5		LM285H-2.5		LM385Z-2.5
	LM385BS8-2.5		LM385H-2.5		LM385BZ-2.5
	<b>PART MARKING</b>		LM385BH-2.5		(NOTE 2)
	2852		(NOTE 2)		
	3852				
	3852B				

## ELECTRICAL CHARACTERISTICS (See Note 1)

SYMBOL	PARAMETER	CONDITIONS	LM185-2.5/285-2.5			LM385-2.5/385B-2.5			UNITS
			MIN	TYP	MAX	MIN	TYP	MAX	
$V_Z$	Reverse Breakdown Voltage	$T_A = 25^\circ\text{C}$ , $20\mu\text{A} \leq I_R \leq 20\text{mA}$ LM185-2.5/285-2.5 LM385-2.5 LM385B-2.5 (Note 2)	2.462	2.500	2.538	2.425	2.500	2.575	V
$\frac{\Delta V_Z}{\Delta \text{Temp}}$	Average Temperature Coefficient	$20\mu\text{A} \leq I_R \leq 20\text{mA}$ (Note 2)	20			20			ppm/°C
$I_{\text{MIN}}$	Minimum Operating Current	$T_{\text{MIN}} \leq T_A \leq T_{\text{MAX}}$	●	8	20	8	20		μA
$\frac{\Delta V_Z}{\Delta I_R}$	Reverse Breakdown Voltage Change With Current	$20\mu\text{A} \leq I_R \leq 1\text{mA}$ $T_A = 25^\circ\text{C}$ $T_{\text{MIN}} \leq T_A \leq T_{\text{MAX}}$	●		1.0		2.0		mV
		$1\text{mA} \leq I_R \leq 20\text{mA}$ $T_A = 25^\circ\text{C}$ $T_{\text{MIN}} \leq T_A \leq T_{\text{MAX}}$	●		1.5		2.5		mV
		$1\text{mA} \leq I_R \leq 20\text{mA}$ $T_A = 25^\circ\text{C}$ $T_{\text{MIN}} \leq T_A \leq T_{\text{MAX}}$	●		10		20		mV
$r_Z$	Reverse Dynamic Impedance	$I_R = 100\mu\text{A}$ (Note 3) $T_A = 25^\circ\text{C}$ $T_{\text{MIN}} \leq T_A \leq T_{\text{MAX}}$	●	0.2	0.6	0.4	1.0		Ω
					1.5		1.5		Ω
$e_n$	Wide Band Noise (RMS)	$10\text{Hz} \leq f \leq 10\text{kHz}$ , $I_R = 100\mu\text{A}$		120		120			μV
$\frac{\Delta V_Z}{\Delta \text{Time}}$	Long Term Stability	$T_A = 25^\circ\text{C} \pm 0.1^\circ\text{C}$ , $I_R = 100\mu\text{A}$		20		20			ppm/kHr

The ● denotes specifications which apply over the operating temperature range.

**Note 1:** All specifications are for  $T_A = 25^\circ\text{C}$  unless otherwise noted. For the LM185-2.5  $T_{\text{MIN}} = -55^\circ\text{C}$  and  $T_{\text{MAX}} = 125^\circ\text{C}$ . For LM285-2.5,  $T_{\text{MIN}} = -40^\circ\text{C}$  and  $T_{\text{MAX}} = 85^\circ\text{C}$ . For LM385-2.5,  $T_{\text{MIN}} = 0^\circ\text{C}$  and  $T_{\text{MAX}} = 70^\circ\text{C}$ .

**Note 2:** For very low initial tolerance, consult LT1004 data sheet. The LT1004 is a low cost, pin for pin substitution device. For guaranteed temperature coefficient consult the LT1034-2.5 data sheet.

**Note 3:** Guaranteed but not tested.

# TYPICAL PERFORMANCE CHARACTERISTICS

Reverse Characteristics

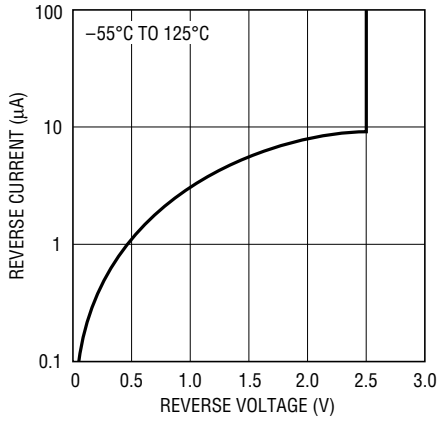

LM185-2.5 • TPC01

Forward Characteristics

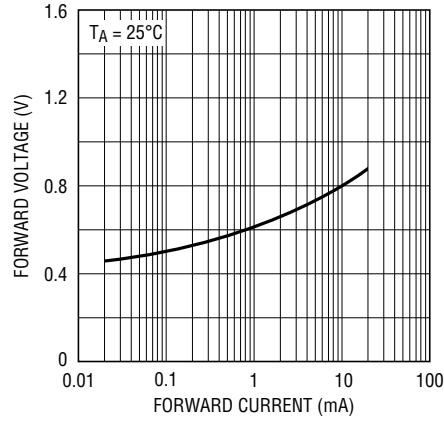

LM185-2.5 • TPC02

Temperature Drift

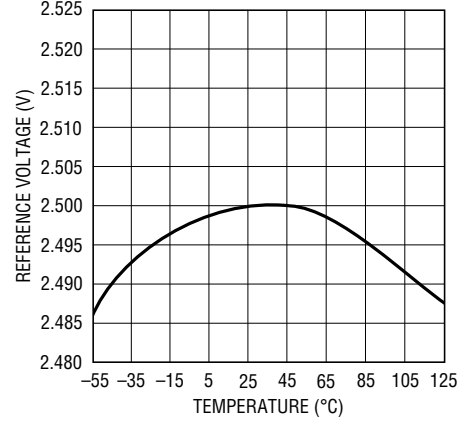

LM185-2.5 • TPC03

Reverse Dynamic Impedance

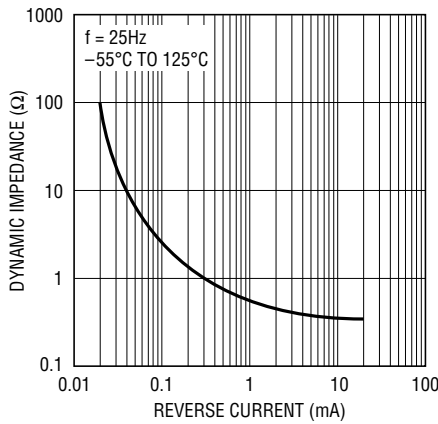

LM185-2.5 • TPC05

Reverse Dynamic Impedance

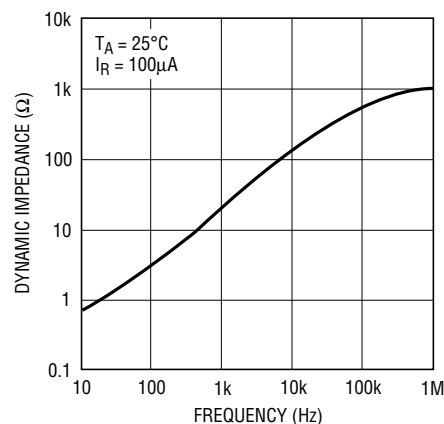

LM185-2.5 • TPC05

Noise Voltage

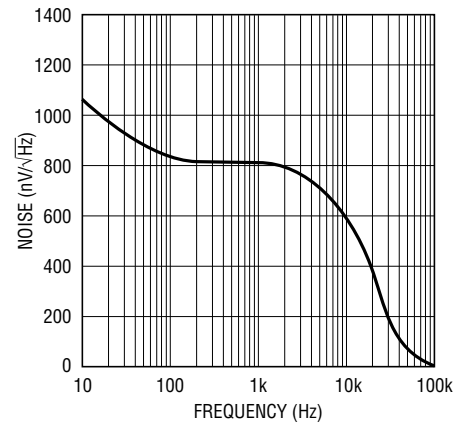

LM185-2.5M • TPC06

Filtered Output Noise

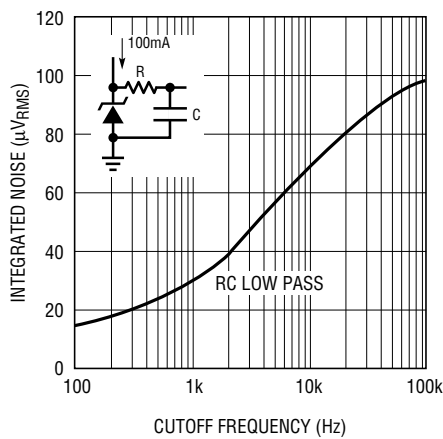

LM185-2.5 • TPC07

Response Time

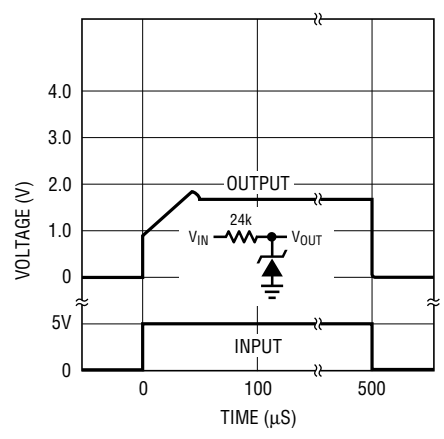

LM185-2.5 • TPC08

# LM185-2.5/ LM285-2.5/LM385-2.5

## SCHEMATIC DIAGRAM

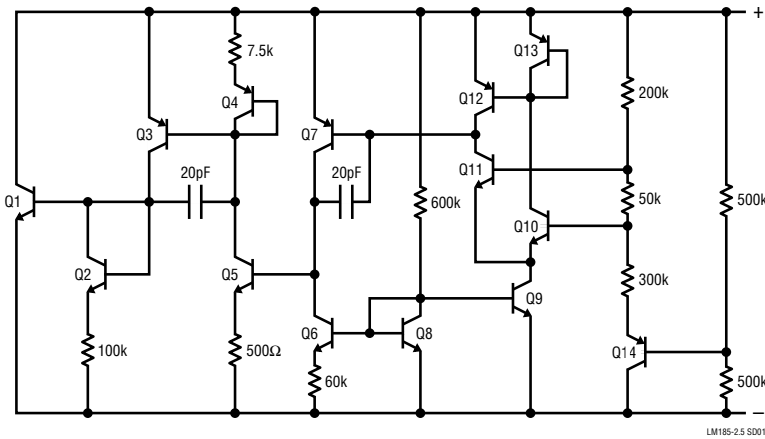

## TYPICAL APPLICATIONS

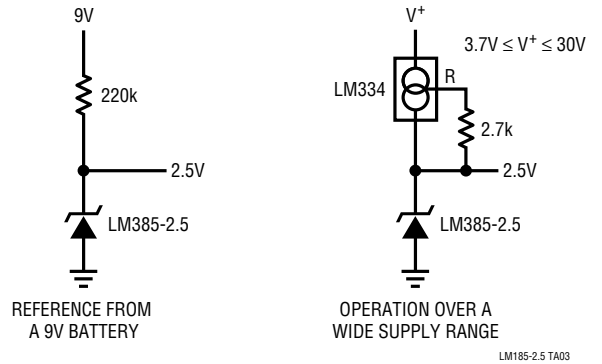

## PACKAGE DESCRIPTION Dimensions in inches (millimeters) unless otherwise noted.

### H Package, 2-Lead TO-46 Metal Can

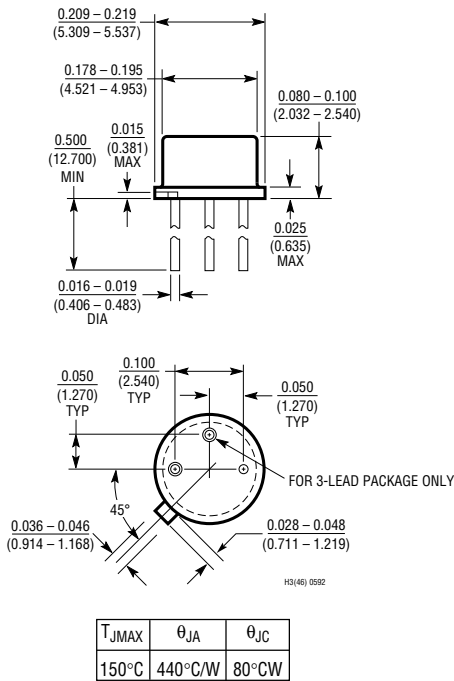

### Z package, 3-Lead TO-92 Plastic

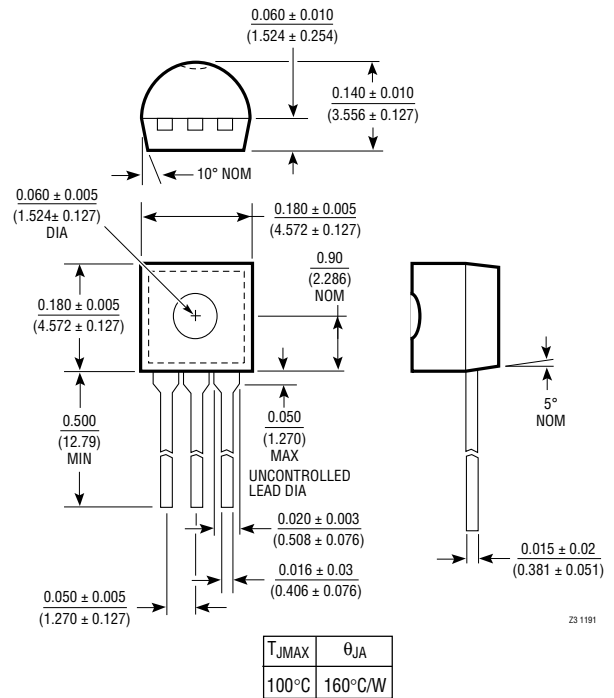

### S8 package, 8-Lead Plastic SOIC

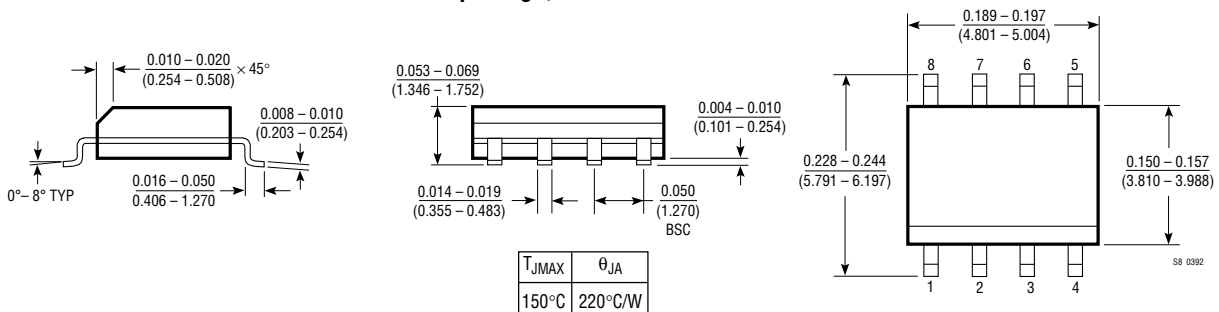

This datasheet has been downloaded from:

[www.DatasheetCatalog.com](http://www.DatasheetCatalog.com)

Datasheets for electronic components.