

This datasheet describes configuration devices for SRAM-based look-up table (LUT) devices.

## Supported Devices

Table 1 lists the supported Altera® configuration devices.

**Table 1. Altera Configuration Devices**

Device	Memory Size (Bits)	ISP Support	Cascaded Support	Reprogrammable	Recommended Operating Voltage (V)
EPC1	1,046,496	No	Yes	No	5.0 or 3.3
EPC2	1,695,680	Yes	Yes	Yes	5.0 or 3.3
EPC1064	65,536	No	No	No	5.0
EPC1064V	65,536	No	No	No	3.3
EPC1213	212,942	No	Yes	No	5.0
EPC1441	440,800	No	No	No	5.0 or 3.3

## Features

Configuration devices for SRAM-based LUT devices offer the following features:

- Configures Altera ACEX® 1K, APEX™ 20K (including APEX 20K, APEX 20KC, and APEX 20KE), APEX II, Arria® GX, Cyclone®, Cyclone II, FLEX® 10K (including FLEX 10KE and FLEX 10KA) Mercury™, Stratix®, Stratix GX, Stratix II, and Stratix II GX devices
- Easy-to-use four-pin interface
- Low current during configuration and near-zero standby mode current
- Programming support with the Altera Programming Unit (APU) and programming hardware from Data I/O, BP Microsystems, and other third-party programmers
- Available in compact plastic packages
  - 8-pin plastic dual in-line (PDIP) package
  - 20-pin plastic J-lead chip carrier (PLCC) package
  - 32-pin plastic thin quad flat pack (TQFP) package
- EPC2 device has reprogrammable flash configuration memory

- 5.0-V and 3.3-V in-system programmability (ISP) through the built-in IEEE Std. 1149.1 JTAG interface
- Built-in JTAG boundary-scan test (BST) circuitry compliant with IEEE Std. 1149.1
- Supports programming through Serial Vector Format File (.svf), Jam™ Standard Test and Programming Language (STAPL) Format File (.jam), JAM Byte Code File (.jbc), and the Quartus® II and MAX+PLUS® II softwares using the USB-Blaster™, MasterBlaster™, ByteBlaster™ II, EthernetBlaster, or ByteBlasterMV™ download cable
- Supports programming through Programmer Object File (.pof) for EPC1 and EPC1441 devices
- nINIT\_CONF pin allows INIT\_CONF JTAG instruction to begin FPGA configuration

 For more information about enhanced configuration (EPC) devices, refer to the [Enhanced Configuration \(EPC\) Devices Datasheet](#).

 For more information about serial configuration (EPCS) devices, refer to the [Serial Configuration \(EPCS\) Devices Datasheet](#).

## Functional Description

With SRAM-based devices, configuration data must be reloaded each time the device powers up, the system initializes, or when new configuration data is needed. Altera configuration devices store configuration data for SRAM-based ACEX 1K, APEX 20K, APEX II, Arria GX, Cyclone, Cyclone II, FLEX 10K, FLEX 6000, Mercury, Stratix, Stratix GX, Stratix II, and Stratix II GX devices.

[Table 2](#) lists the supported configuration devices required to configure the ACEX 1K, APEX 20K, APEX 20KC, APEX 20KE, APEX II, Cyclone, Cyclone II, FLEX 10K, FLEX 10KA, FLEX 10KE, FLEX 6000/A, FLEX 8000A, Mercury, Stratix, Stratix GX, or Stratix II device.

**Table 2. Supported Configuration Devices (Part 1 of 4)**

Device Family	Device	Data Size (Bits) (1)	EPC1064 or EPC1064V	EPC1213	EPC1441	EPC1	EPC2
ACEX 1K	EP1K10	159,160	—	—	1	1	1
	EP1K30	473,720	—	—	—	1	1
	EP1K50	784,184	—	—	—	1	1
	EP1K100	1,335,720	—	—	—	—	1
APEX 20K	EP20K100	993,360	—	—	—	1	1
	EP20K200	1,950,800	—	—	—	—	2
	EP20K400	3,880,720	—	—	—	—	3
APEX 20KC	EP20K200C	1,968,016	—	—	—	—	2
	EP20K400C	3,909,776	—	—	—	—	3
	EP20K600C	5,673,936	—	—	—	—	4
	EP20K1000C	8,960,016	—	—	—	—	6

Table 2. Supported Configuration Devices (Part 2 of 4)

Device Family	Device	Data Size (Bits) (1)	EPC1064 or EPC1064V	EPC1213	EPC1441	EPC1	EPC2
APEX 20KE	EP20K30E	354,832	—	—	1	1	1
	EP20K60E	648,016	—	—	—	1	1
	EP20K100E	1,008,016	—	—	—	1	1
	EP20K160E	1,524,016	—	—	—	—	1
	EP20K200E	1,968,016	—	—	—	—	2
	EP20K300E	2,741,616	—	—	—	—	2
	EP20K400E	3,909,776	—	—	—	—	3
	EP20K600E	5,673,936	—	—	—	—	4
	EP20K1000E	8,960,016	—	—	—	—	6
	EP20K1500E	12,042,256	—	—	—	—	8
APEX II	EP2A15	1,168,688	—	—	—	—	3
	EP2A25	1,646,544	—	—	—	—	4
	EP2A40	2,543,016	—	—	—	—	6
	EP2A70	4,483,064	—	—	—	—	11
Cyclone	EP1C3	627,376	—	—	—	1	1
	EP1C4	925,000	—	—	—	1	1
	EP1C6	1,167,216	—	—	—	1 (2)	1
	EP1C12	2,326,528	—	—	—	—	1 (2)
	EP1C20	3,559,608	—	—	—	—	2 (2)
Cyclone II	EP2C5	1,265,792	—	—	—	—	1
	EP2C8	1,983,536	—	—	—	—	2
	EP2C20	3,892,496	—	—	—	—	3
	EP2C35	6,848,608	—	—	—	—	5
	EP2C50	9,951,104	—	—	—	—	6
	EP2C70	14,319,216	—	—	—	—	9
FLEX 10K	EPF10K10	118,000	—	—	1	1	1
	EPF10K20	231,000	—	—	1	1	1
	EPF10K30	376,000	—	—	1	1	1
	EPF10K40	498,000	—	—	—	1	1
	EPF10K50	621,000	—	—	—	1	1
	EPF10K70	892,000	—	—	—	1	1
	EPF10K100	1,200,000	—	—	—	—	1
FLEX 10KA	EPF10K10A	120,000	—	—	1	1	1
	EPF10K30A	406,000	—	—	1	1	1
	EPF10K50V	621,000	—	—	—	1	1
	EPF10K100A	1,200,000	—	—	—	—	1
	EPF10K130V	1,600,000	—	—	—	—	1
	EPF10K250A	3,300,000	—	—	—	—	2

**Table 2. Supported Configuration Devices (Part 3 of 4)**

Device Family	Device	Data Size (Bits) (1)	EPC1064 or EPC1064V	EPC1213	EPC1441	EPC1	EPC2
FLEX 10KE	EPF10K30E	473,720	—	—	—	1	1
	EPF10K50E	784,184	—	—	—	1	1
	EPF10K50S	784,184	—	—	—	1	1
	EPF10K100B	1,200,000	—	—	—	—	1
	EPF10K100E	1,335,720	—	—	—	—	1
	EPF10K130E	1,838,360	—	—	—	—	2
	EPF10K200E	2,756,296	—	—	—	—	2
	EPF10K200S	2,756,296	—	—	—	—	2
FLEX 6000/A	EPF6010A	260,000	—	—	1	1	—
	EPF6016(5.0 V)/ EPF6016A	260,000	—	—	1	1	—
	EPF6024A	398,000	—	—	1	1	—
FLEX 8000A	EPF8282A / EPF8282AV(3.3 V)	40,000	1	1	1	1	—
	EPF8452A	64,000	1	1	1	1	—
	EPF8636A	96,000	—	1	1	1	—
	EPF8820A	128,000	—	1	1	1	—
	EPF81188A	192,000	—	1	1	1	—
	EPF81500A	250,000	—	—	1	1	—
Mercury	EP1M120	1,303,120	—	—	—	—	1
	EP1M350	4,394,032	—	—	—	—	3
Stratix	EP1S10	3,534,640	—	—	—	—	3 (3)
	EP1S20	5,904,832	—	—	—	—	4
	EP1S25	7,894,144	—	—	—	—	5
	EP1S30	10,379,368	—	—	—	—	7
	EP1S40	12,389,632	—	—	—	—	8
	EP1S60	17,543,968	—	—	—	—	11
	EP1S80	23,834,032	—	—	—	—	15
Stratix GX	EP1SGX10	3,534,640	—	—	—	—	3
	EP1SGX25	7,894,144	—	—	—	—	5
	EP1SGX40	12,389,632	—	—	—	—	8

**Table 2. Supported Configuration Devices (Part 4 of 4)**

Device Family	Device	Data Size (Bits) (1)	EPC1064 or EPC1064V	EPC1213	EPC1441	EPC1	EPC2
Stratix II	EP2S15	5,000,000	—	—	—	—	3
	EP2S30	10,100,000	—	—	—	—	7
	EP2S60	17,100,000	—	—	—	—	11
	EP2S90	27,500,000	—	—	—	—	17
	EP2S130	39,600,000	—	—	—	—	24
	EP2S180	52,400,000	—	—	—	—	31

**Notes to Table 2:**

- (1) Raw Binary File (.rbf) were used to determine these sizes.
- (2) This number is calculated with the Cyclone series compression feature enabled.
- (3) EP1S10 ES devices requires four EPC2 devices.

Figure 1 shows the configuration device block diagram.

**Figure 1. Configuration Device Block Diagram**

**FPGA (except FLEX 8000) Configuration Using an EPC2, EPC1, or EPC1441**

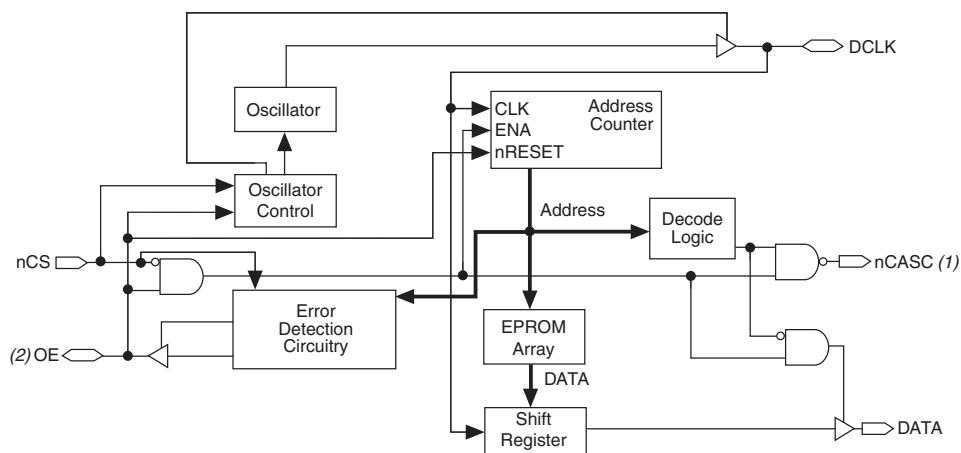

**FLEX 8000 Device Configuration Using an EPC1, EPC1441, EPC1213, EPC1064, or EPC1064V**

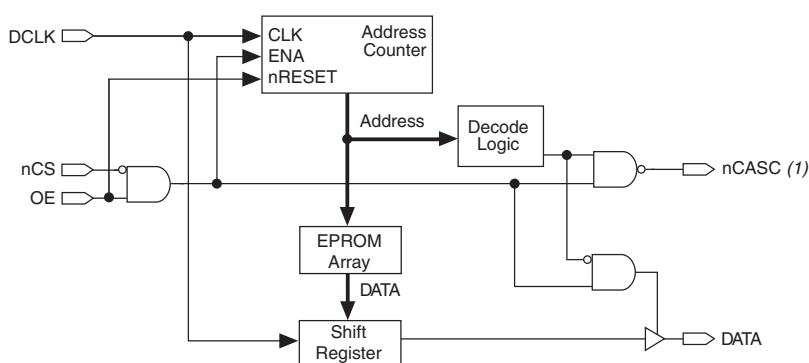

**Notes to Figure 1:**

- (1) The EPC1441 devices do not support data cascading. The EPC1, EPC2, and EPC1213 devices support data cascading.
- (2) The OE pin is a bidirectional open-drain pin.

## Device Configuration

The EPC1, EPC2, and EPC1441 devices store configuration data in its erasable programmable read-only memory (EPROM) array and serially clock data out using an internal oscillator. The OE, nCS, and DCLK pins supply the control signals for the address counter and the DATA output tri-state buffer. The configuration device sends a serial bitstream of configuration data to its DATA pin, which is routed to the DATA0 input of the FPGA.

The control signals for configuration devices, OE, nCS, and DCLK, interface directly with the FPGA control signals, nSTATUS, CONF\_DONE, and DCLK. All Altera FPGAs can be configured by a configuration device without requiring an external intelligent controller.

 An EPC2 device cannot configure FLEX 8000 or FLEX 6000 devices. For configuration devices that support FLEX 8000 or FLEX 6000 devices, refer to [Table 2](#).

[Figure 2](#) shows the basic configuration interface connections between the configuration device and the Altera FPGA.

**Figure 2. Altera FPGA Configured Using an EPC1, EPC2, or EPC1441 Configuration Device <sup>(1)</sup>**

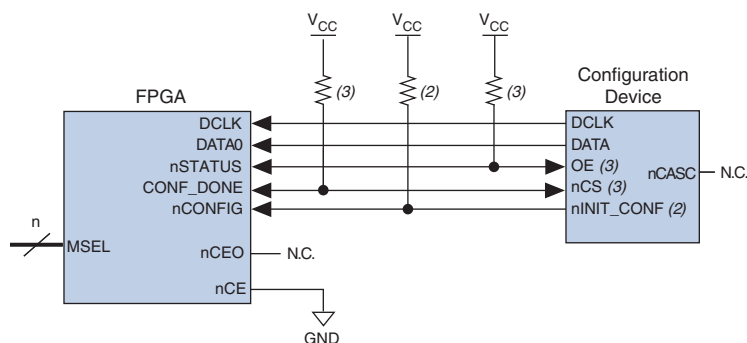

### Notes to [Figure 2](#):

- (1) For more information about configuration interface connections, refer to the configuration chapter in the appropriate device handbook.
- (2) The nINIT\_CONF pin which is available on EPC2 devices has an internal pull-up resistor that is always active. This means an external pull-up resistor is not required on the nINIT\_CONF/nCONFIG line. The nINIT\_CONF pin does not need to be connected if its functionality is not used. If the nINIT\_CONF pin is not used or unavailable, nCONFIG must be pulled to V<sub>CC</sub> either directly or through a resistor.
- (3) EPC2 devices have internal programmable pull-up resistors on OE and nCS pins. If internal pull-up resistors are used, do not use external pull-up resistors on these pins. The internal pull-up resistors are set by default in the Quartus II software. To turn off the internal pull-up resistors, check the **Disable nCS and OE pull-ups on configuration device** option when you generate programming files.

The EPC2 device allows you to begin configuration of the FPGA using an additional pin, nINIT\_CONF. The nINIT\_CONF pin of the EPC2 device can be connected to the nCONFIG pin of the FPGA, which allows the INIT\_CONF JTAG instruction to begin FPGA configuration. The INIT\_CONF JTAG instruction causes the EPC2 device to drive the nINIT\_CONF pin low, which in turn pulls the nCONFIG pin low. Pulling the nCONFIG pin low on the FPGA will reset the device. When the JTAG state machine exits this state, the nINIT\_CONF pin is released and pulled high by an internal 1-kΩ resistor, which in turn pulls the nCONFIG pin high to begin configuration. If you do not use the nINIT\_CONF pin, disconnect the nINIT\_CONF pin, and pull the nCONFIG pin of the FPGA to V<sub>CC</sub> either directly or through a resistor.

The EPC2 device's OE and nCS pins have internal programmable pull-up resistors. If you use internal pull-up resistors, do not use external pull-up resistors on these pins. The internal pull-up resistors are set by default in the Quartus II software. To turn off the internal pull-up resistors, check the **Disable nCS and OE pull-ups on configuration device** option when you generate programming files.

The configuration device's OE and nCS pins control the tri-state buffer on its DATA output pin and enable the address counter and oscillator. When the OE pin is driven low, the configuration device resets the address counter and tri-states its DATA pin. The nCS pin controls the DATA output of the configuration device. If the nCS pin is held high after the OE reset pulse, the counter is disabled and the DATA output pin is tri-stated. If the nCS pin is driven low after the OE reset pulse, the counter and DATA output pin are enabled. When OE is driven low again, the address counter is reset and the DATA output pin is tri-stated, regardless of the state of the nCS pin.

If the FPGA's configuration data exceeds the capacity of a single EPC1 or EPC2 configuration device, you can cascade multiple EPC1 or EPC2 devices together. If multiple EPC1 or EPC2 devices are required, the nCASC and nCS pins provide handshaking between the configuration devices.



EPC1441 and EPC1064/EPC1064V devices cannot be cascaded.

When configuring ACEX 1K, APEX 20K, APEX II, Arria GX, Cyclone, Cyclone II, FLEX 10K, Mercury, Stratix, Stratix GX, Stratix II, and Stratix II GX devices with cascaded EPC1 or EPC2 devices, the position of the EPC1 or EPC2 device in the chain determines its mode of operation. The first configuration device in the chain is the master, while subsequent configuration devices are slaves. The nINIT\_CONF pin of the EPC2 master device can be connected to the nCONFIG pin of the FPGAs, which allows the INIT\_CONF JTAG instruction to begin FPGA configuration. The nCS pin of the master configuration device is connected to the CONF\_DONE pin of the FPGAs, while its nCASC pin is connected to the nCS pin of the next slave configuration device in the chain. Additional EPC1 or EPC2 devices can be chained together by connecting the nCASC pin to the nCS pin of the next EPC1 or EPC2 slave device in the chain. The last device's nCS input comes from the previous device, while its nCASC pin is left floating. All other configuration pins, DCLK, DATA, and OE, are connected to every device in the chain.



For more information about configuration interface connections, including pull-up resistor values, supply voltages, and MSEL pin setting, refer to the configuration chapter in the appropriate device handbook.



configuration bit was sent for the CONF\_DONE pin to reach a high state. In this case, the configuration device pulls its OE pin low, which in turn drives the target device's nSTATUS pin low. Configuration automatically restarts if the **Auto-restart configuration on error** option is turned on in the Quartus II software from the **General** tab of the **Device & Pin Options** dialog box or the MAX+PLUS II software's **Global Project Device Options** dialog box (Assign menu).

 For more information about FPGA configuration and configuration interface connections between configuration devices and Altera FPGAs, refer to the configuration chapter in the appropriate device handbook.

## Power and Operation

This section describes power-on reset (POR) delay, error detection, and 3.3-V and 5.0-V operation of Altera configuration devices.

### Power-On Reset

During initial power-up, a POR delay occurs to permit voltage levels to stabilize. When configuring an FPGA with one EPC1, EPC2, or EPC1441 device, the POR delay occurs inside the configuration device and the POR delay is a maximum of 200 ms. When configuring a FLEX 8000 device with one EPC1213, EPC1064, or EPC1064V device, the POR delay occurs inside the FLEX 8000 device and the POR delay is typically 100 ms, with a maximum of 200 ms.

During POR, the configuration device drives its OE pin low. This low signal delays configuration because the OE pin is connected to the target FPGA's nSTATUS pin. When the configuration device completes POR, it releases its open-drain OE pin, which is then pulled high by a pull-up resistor.

 You should power up the FPGA before the configuration device exits POR to avoid the master configuration device from entering slave mode.

If the FPGA is not powered up before the configuration device exits POR, the CONF\_DONE/ nCS line is high because of the pull-up resistor. When the configuration device exits POR and releases OE, it sees nCS high, which signals the configuration device to enter slave mode. Therefore, configuration will not begin because the DATA output is tri-stated and DCLK is an input pin in slave mode.

### Error Detection Circuitry

The EPC1, EPC2, and EPC1441 configuration devices have built-in error detection circuitry for configuring ACEX 1K, APEX 20K, APEX II, Arria GX, Cyclone, Cyclone II, FLEX 10K, FLEX 6000, Mercury, Stratix, Stratix GX, Stratix II, or Stratix II GX devices.

Built-in error detection circuitry uses the nCS pin of the configuration device, which monitors the CONF\_DONE pin on the FPGA. If the nCS pin on the EPC1 or EPC2 master device is driven high before all configuration data is transferred, the EPC1 or EPC2 master device drives its OE signal low, which in turn drives the FPGA's nSTATUS pin low, indicating a configuration error. Additionally, if the configuration device generates its data and detects that the CONF\_DONE pin has not gone high, it recognizes

that the FPGA has not configured successfully. EPC1 and EPC2 devices wait for 16 DCLK cycles after the last configuration bit was sent for the CONF\_DONE pin to reach a high state. In this case, the configuration device pulls its OE pin low, which in turn drives the target device's nSTATUS pin low. Configuration automatically restarts if the **Auto-restart configuration on error** option is turned on in the Quartus II software from the **General** tab of the **Device & Pin Options** dialog box or the MAX+PLUS II software's **Global Project Device Options** dialog box (Assign menu).

In addition, if the FPGA detects a cyclic redundancy check (CRC) error in the received data, it will flag the error by driving the nSTATUS signal low. This low signal on nSTATUS drives the OE pin of the configuration device low, which resets the configuration device. CRC checking is performed when configuring all Altera FPGAs.

### 3.3-V or 5.0-V Operation

Power the EPC1, EPC2, and EPC 1441 configuration device at 3.3 V or 5.0 V. For each configuration device, an option must be set for the 3.3-V or 5.0-V operation.

For EPC1 and EPC1441 configuration devices, 3.3-V or 5.0-V operation is controlled by a programming bit in the .pof. The **Low-Voltage mode** option in the Options tab of the Configuration Device Options dialog box in the Quartus II software or the **Use Low-Voltage Configuration EPROM** option in the **Global Project Device Options** dialog box (Assign menu) in the MAX+PLUS II software sets this parameter. For example, EPC1 devices are programmed automatically to operate in 3.3-V mode when configuring FLEX 10KA devices, which have a V<sub>CC</sub> voltage of 3.3 V. In this example, the EPC1 device's VCC pin is connected to a 3.3-V power supply.

For EPC2 devices, this option is set externally by the VCCSEL pin. In addition, the EPC2 device has an externally controlled option, set by the VPPSEL pin, to adjust the programming voltage to 5.0 V or 3.3 V. The functions of the VCCSEL and VPPSEL pins are described below. These pins are only available in the EPC2 devices.

- VCCSEL pin—For EPC2 configuration devices, 5.0-V or 3.3-V operation is controlled by the VCCSEL option pin. The device functions in 5.0-V mode when VCCSEL is connected to GND and 3.3-V mode when VCCSEL is connected to V<sub>CC</sub>.
- VPPSEL pin—The V<sub>PP</sub> programming power pin of the EPC2 device is normally tied to V<sub>CC</sub>. For EPC2 devices operating at 3.3 V, it is possible to improve ISP time by setting V<sub>PP</sub> to 5.0 V. For all other configuration devices, V<sub>PP</sub> must be tied to V<sub>CC</sub>. The VPPSEL pin of the EPC2 device must be set in accordance with the VPP pin of the EPC2 device. If the VPP pin is supplied by a 5.0-V power supply, VPPSEL must be connected to GND and if the VPP pin is supplied by a 3.3-V power supply, VPPSEL must be connected to V<sub>CC</sub>.

Table 3 lists the relationship between the  $V_{CC}$  and  $V_{PP}$  voltage levels and the required logic level for VCCSEL and VPPSEL pins. A high logic level means the pin should be connected to  $V_{CC}$ , while a low logic level means the pin should be connected to GND.

**Table 3. VCCSEL and VPPSEL Pin Functions on the EPC2 Device**

VCC Voltage Level (V)	VPP Voltage Level (V)	VCCSEL Pin Logic Level	VPPSEL Pin Logic Level
3.3	3.3	High	High
3.3	5.0	High	Low
5.0	5.0	Low	Low

At a 3.3-V operation, all EPC2 inputs are 5.0-V tolerant, except for DATA, DCLK, and  $n$ CASC pins. The DATA and DCLK pins are used only to interface between the EPC2 device and the FPGA it is configuring. Table 4 lists the voltage tolerances of all EPC2 device pins.

**Table 4. EPC2 Device Input and Bidirectional Pin Voltage Tolerance**

Pin	5.0-V Operation		3.3-V Operation	
	5.0-V Tolerant	3.3-V Tolerant	5.0-V Tolerant	3.3-V Tolerant
DATA	✓	✓	—	✓
DCLK	✓	✓	—	✓
$n$ CASC	✓	✓	—	✓
OE	✓	✓	✓	✓
$n$ CS	✓	✓	✓	✓
VCCSEL	✓	✓	✓	✓
VPPSEL	✓	✓	✓	✓
$n$ INIT_CONF	✓	✓	✓	✓
TDI	✓	✓	✓	✓
TMS	✓	✓	✓	✓
TCK	✓	✓	✓	✓

If one EPC1, EPC2, or EPC1441 configuration device is powered at 3.3 V, the  $n$ STATUS and CONF\_DONE pull-up resistors must be connected to 3.3 V. If these configuration devices are powered at 5.0 V, the  $n$ STATUS and CONF\_DONE pull-up resistors can be connected to either 3.3 V or 5.0 V.

## Programming and Configuration File Support

The Quartus II and MAX+PLUS II softwares provide programming support for Altera configuration devices. During compilation, the Quartus II and MAX+PLUS II softwares automatically generates a **.pof**, which is used to program the configuration devices. In a multi-device configuration, the software combines the programming files for multiple ACEX 1K, APEX 20K, APEX II, Arria GX, Cyclone, Cyclone II, FLEX 10K, Mercury, Stratix, Stratix GX, Stratix II, and Stratix II GX devices into one or more configuration devices. The software allows you to select the appropriate configuration device to store the data for each FPGA.

All Altera configuration devices are programmable using Altera programming hardware in conjunction with the Quartus II or MAX+PLUS II software. In addition, many third-party programmers offer programming hardware that supports Altera configuration devices.



An EPC2 device can be programmed with a **.pof** generated for an EPC1 or EPC1441 device. An EPC1 device can be programmed with a **.pof** generated for an EPC1441 device.

EPC2 configuration devices can be programmed in-system through its industry-standard four-pin JTAG interface. ISP capability in the EPC2 devices provide ease in prototyping and FPGA functionality. When programming multiple EPC2 devices in a JTAG chain, the Quartus II and MAX+PLUS II softwares and other programming methods employ concurrent programming to simultaneously program multiple devices and reduce programming time. EPC2 devices can be programmed and erased up to 100 times.

After programming an EPC2 device in-system, FPGA configuration is initiated by the INIT\_CONF JTAG instruction of the EPC2 device. For more information, refer to [Table 6](#).



For more information about programming and configuration support, refer to the following documents:

- [Altera Programming Hardware Data Sheet](#)
- [USB-Blaster Download Cable User Guide](#)
- [MasterBlaster Serial/USB Communications Cable User Guide](#)
- [ByteBlaster II Download Cable User Guide](#)
- [ByteBlasterMV Download Cable User Guide](#)
- [BitBlaster Serial Download Cable Data Sheet](#)

You can also program the configuration devices using the Quartus II or MAX+PLUS II software with the APU or the appropriate configuration device programming adapter.

Table 5 lists the programming adapter to use with each configuration device.

**Table 5. Programming Adapters**

Device	Package	Adapter
EPC2	20-pin J-Lead	PLMJ1213
	32-pin TQFP	PLMT1213
EPC1	8-pin DIP	PLMJ1213
	20-pin J-Lead	PLMJ1213
EPC1441	8-pin DIP	PLMJ1213
	20-pin J-Lead	PLMJ1213
	32-pin TQFP	PLMT1064

To program Altera configuration devices using the Quartus II software and the APU, follow these steps:

1. Choose the **Quartus II Programmer** (Tools menu).
2. Load the appropriate **.pof** by clicking **Add**. The **Device** column displays the device for the current programming file.
3. Insert a blank configuration device into the programming adapter's socket.
4. Turn on the **Program/Configure**. You can also turn on **Verify** to verify the contents of a programmed device against the programming data loaded from a programming file.
5. Click **Start**.
6. After successful programming, you can place the configuration device on the PCB to configure the FPGA device.

To program Altera configuration devices using the MAX+PLUS II software and the APU, follow these steps:

1. Open the MAX+PLUS II Programmer.
2. Load the appropriate **.pof** using the **Select Programming File** dialog box (File menu). By default, the **Programmer** loads the current project's **.pof**. The **Device** field displays the device for the current programming file.
3. Insert a blank configuration device into the programming adapter's socket.
4. Click **Program**.
5. After successful programming, you can place the configuration device on the PCB to configure the FPGA device.

If you are cascading EPC1 or EPC2 devices, you must generate multiple **.pof**. The first device **.pof** have the same name as the project, while the second device **.pof** have the same name as the first, but with a "\_1" extension (e.g., **top\_1.pof**).

## IEEE Std. 1149.1 (JTAG) Boundary-Scan Testing

The EPC2 device provides JTAG BST circuitry that complies with the IEEE Std. 1149.1-1990 specification. You can perform JTAG BST before or after configuration, but not during configuration. Table 6 lists the JTAG instructions supported by the EPC2 device.

**Table 6. EPC2 Device JTAG Instructions**

JTAG Instruction	OPCODE	Description
SAMPLE/PRELOAD	00 0101 0101	Allows a snapshot of a signal at the device pins to be captured and examined during normal device operation and permits an initial data pattern output at the device pins.
EXTEST	00 0000 0000	Allows the external circuitry and board-level interconnections to be tested by forcing a test pattern at the output pins and capturing results at the input pins.
BYPASS	11 1111 1111	Places the 1-bit bypass register between the TDI and TDO pins, which allows the BST data to pass synchronously through a selected device to adjacent devices during normal device operation.
IDCODE	00 0101 1001	Selects the device IDCODE register and places it between the TDI and TDO pins, allowing the device IDCODE to be serially shifted out of the TDO pin. The device IDCODE for the EPC2 configuration device is shown below: 0000 0001000000000010 00001101110 1
USERCODE	00 0111 1001	Selects the USERCODE register and places it between the TDI and TDO pins, allowing the USERCODE to be serially shifted out of the TDO pin. The 32-bit USERCODE is a programmable user-defined pattern.
INIT_CONF	00 0110 0001	Initiates the FPGA re-configuration process by pulsing the <i>n</i> INIT_CONF pin low, which is connected to the FPGAs <i>n</i> CONFIG pins. After this instruction is updated, the <i>n</i> INIT_CONF pin is pulsed low when the JTAG state machine enters the Run-Test/Idle state. The <i>n</i> INIT_CONF pin is then released and <i>n</i> CONFIG is pulled high by the resistor after the JTAG state machine goes out of Run-Test/Idle state. The FPGA configuration starts after the <i>n</i> CONFIG pin goes high. As a result, the FPGA is configured with the new configuration data stored in the configuration device. You can add this function to your programming file (.pof, .jam, .jbc) in the Quartus II software by enabling the <b>Initiate configuration after programming</b> option in the Programmer options window (Options menu). This instruction is also used by the MAX+PLUS II software, .jam files, and .jbc files.
ISP Instructions	—	These instructions are used when programming an EPC2 device using JTAG ports with a USB-Blaster, MasterBlaster, ByteBlaster II, EthernetBlaster, or ByteBlasterMV download cable, or using a .jam, .jbc, or .svf file using an embedded processor.

 For more information, refer to [AN39: IEEE 1149.1 JTAG Boundary-Scan Testing in Altera Devices](#).

Figure 4 shows the timing requirements for the JTAG signals.

**Figure 4. EPC2 Device JTAG Waveforms**

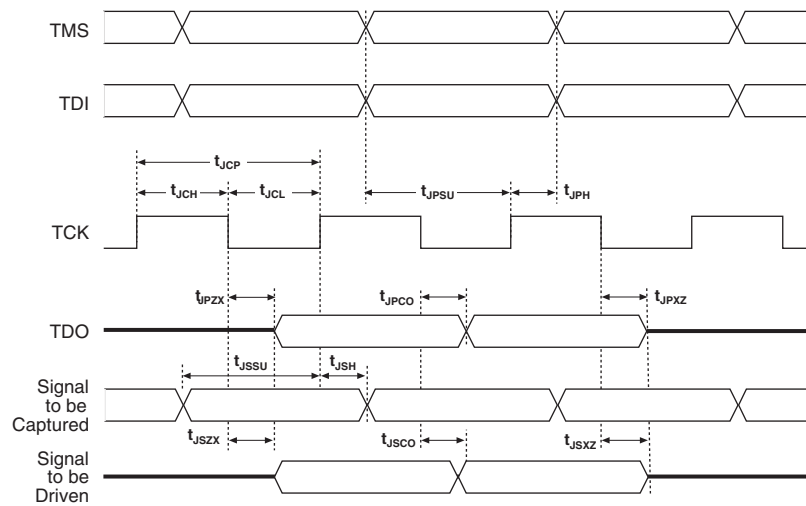

Table 7 lists the timing parameters and values for configuration devices.

**Table 7. JTAG Timing Parameters and Values**

Symbol	Parameter	Min	Max	Unit
$t_{JCP}$	TCK clock period	100	—	ns
$t_{JCH}$	TCK clock high time	50	—	ns
$t_{JCL}$	TCK clock low time	50	—	ns
$t_{JPSU}$	JTAG port setup time	20	—	ns
$t_{JPH}$	JTAG port hold time	45	—	ns
$t_{JPCO}$	JTAG port clock to output	—	25	ns
$t_{JPZX}$	JTAG port high impedance to valid output	—	25	ns
$t_{JPXZ}$	JTAG port valid output to high impedance	—	25	ns
$t_{JSSU}$	Capture register setup time	20	—	ns
$t_{JSH}$	Capture register hold time	45	—	ns
$t_{JSCO}$	Update register clock to output	—	25	ns
$t_{JSZX}$	Update register high impedance to valid output	—	25	ns
$t_{JSXZ}$	Update register valid output to high impedance	—	25	ns

## Timing Information

Figure 5 shows the timing waveform when using a configuration device.

**Figure 5. Timing Waveform Using a Configuration Device**

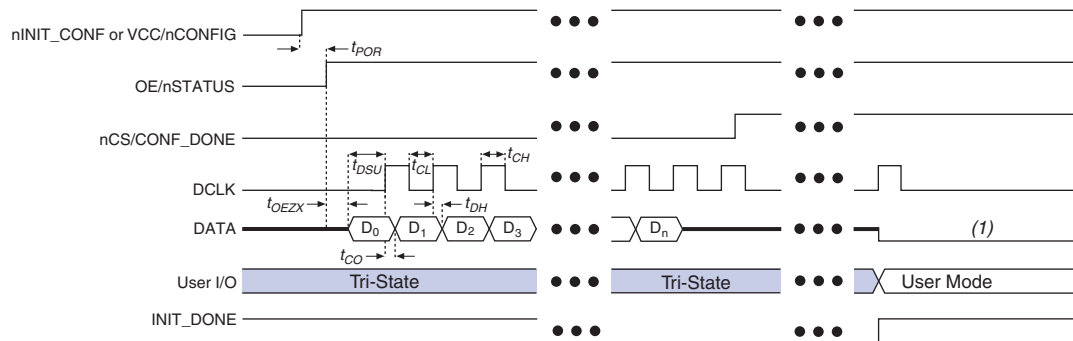

**Note to Figure 5:**

- (1) The EPC2 device drives DCLK low and DATA high after configuration. The EPC1 and EPC1441 devices drive DCLK low and tri-state DATA after configuration.

Table 8 lists the timing parameters when using EPC2 devices at 3.3 V.

**Table 8. Timing Parameters when Using EPC2 devices at 3.3 V**

Symbol	Parameter	Min	Typ	Max	Units
$t_{POR}$	POR delay (1)	—	—	200	ms
$t_{OEZX}$	OE high to DATA output enabled	—	—	80	ns
$t_{CE}$	OE high to first rising edge on DCLK	—	—	300	ns
$t_{DSU}$	Data setup time before rising edge on DCLK	30	—	—	ns
$t_{DH}$	Data hold time after rising edge on DCLK	0	—	—	ns
$t_{CO}$	DCLK to DATA out	—	—	30	ns
$t_{CDOE}$	DCLK to DATA enable/disable	—	—	30	ns
$f_{CLK}$	DCLK frequency	5	7.7	12.5	MHz
$t_{MCH}$	DCLK high time for the first device in the configuration chain	40	65	100	ns
$t_{MCL}$	DCLK low time for the first device in the configuration chain	40	65	100	ns
$t_{SCH}$	DCLK high time for subsequent devices	40	—	—	ns
$t_{SCL}$	DCLK low time for subsequent devices	40	—	—	ns
$t_{CASC}$	DCLK rising edge to nCASC	—	—	25	ns
$t_{CCA}$	nCS to nCASC cascade delay	—	—	15	ns
$t_{OEW}$	OE low pulse width (reset) to guarantee counter reset	100	—	—	ns
$t_{OEC}$	OE low (reset) to DCLK disable delay	—	—	30	ns
$t_{NRCAS}$	OE low (reset) to nCASC delay	—	—	30	ns

**Note to Table 8:**

- (1) During initial power-up, a POR delay occurs to permit voltage levels to stabilize. Subsequent reconfigurations do not incur this delay.

Table 9 lists the timing parameters when using EPC1 and EPC1441 devices at 3.3 V.

**Table 9. Timing Parameters when Using EPC1 and EPC1441 Devices at 3.3 V**

Symbol	Parameter	Min	Typ	Max	Units
t <sub>POR</sub>	POR delay <sup>(1)</sup>	—	—	200	ms
t <sub>OEZX</sub>	OE high to DATA output enabled	—	—	80	ns
t <sub>CE</sub>	OE high to first rising edge on DCLK	—	—	300	ns
t <sub>DSU</sub>	Data setup time before rising edge on DCLK	30	—	—	ns
t <sub>DH</sub>	Data hold time after rising edge on DCLK	0	—	—	ns
t <sub>CO</sub>	DCLK to DATA out	—	—	30	ns
t <sub>CDOE</sub>	DCLK to DATA enable/disable	—	—	30	ns
f <sub>CLK</sub>	DCLK frequency	2	4	10	MHz
t <sub>MCH</sub>	DCLK high time for the first device in the configuration chain	50	125	250	ns
t <sub>MCL</sub>	DCLK low time for the first device in the configuration chain	50	125	250	ns
t <sub>SCH</sub>	DCLK high time for subsequent devices	50	—	—	ns
t <sub>SCL</sub>	DCLK low time for subsequent devices	50	—	—	ns
t <sub>CASC</sub>	DCLK rising edge to nCASC	—	—	25	ns
t <sub>CCA</sub>	nCS to nCASC cascade delay	—	—	15	ns
t <sub>OEW</sub>	OE low pulse width (reset) to guarantee counter reset	100	—	—	ns
t <sub>OEC</sub>	OE low (reset) to DCLK disable delay	—	—	30	ns
t <sub>NRCAS</sub>	OE low (reset) to nCASC delay	—	—	30	ns

**Note to Table 9:**

(1) During initial power-up, a POR delay occurs to permit voltage levels to stabilize. Subsequent reconfigurations do not incur this delay.

Table 10 lists the timing parameters when using EPC1, EPC2, and EPC1441 devices at 5.0 V.

**Table 10. Timing Parameters when Using EPC1, EPC2, and EPC1441 Devices at 5.0 V (Part 1 of 2)**

Symbol	Parameter	Min	Typ	Max	Units
t <sub>POR</sub>	POR delay <sup>(1)</sup>	—	—	200	ms
t <sub>OEZX</sub>	OE high to DATA output enabled	—	—	50	ns
t <sub>CE</sub>	OE high to first rising edge on DCLK	—	—	200	ns
t <sub>DSU</sub>	Data setup time before rising edge on DCLK	30	—	—	ns
t <sub>DH</sub>	Data hold time after rising edge on DCLK	0	—	—	ns
t <sub>CO</sub>	DCLK to DATA out	—	—	20	ns
t <sub>CDOE</sub>	DCLK to DATA enable/disable	—	—	20	ns
f <sub>CLK</sub>	DCLK frequency	6.7	10	16.7	MHz
t <sub>MCH</sub>	DCLK high time for the first device in the configuration chain	30	50	75	ns
t <sub>MCL</sub>	DCLK low time for the first device in the configuration chain	30	50	75	ns
t <sub>SCH</sub>	DCLK high time for subsequent devices	30	—	—	ns
t <sub>SCL</sub>	DCLK low time for subsequent devices	30	—	—	ns
t <sub>CASC</sub>	DCLK rising edge to nCASC	—	—	20	ns
t <sub>CCA</sub>	nCS to nCASC cascade delay	—	—	10	ns

**Table 10. Timing Parameters when Using EPC1, EPC2, and EPC1441 Devices at 5.0 V (Part 2 of 2)**

Symbol	Parameter	Min	Typ	Max	Units
$t_{OE\bar{W}}$	OE low pulse width (reset) to guarantee counter reset	100	—	—	ns
$t_{OE\bar{C}}$	OE low (reset) to DCLK disable delay	—	—	20	ns
$t_{\bar{N}RCAS}$	OE low (reset) to $\bar{n}CASC$ delay	—	—	25	ns

**Note to Table 10:**

(1) During initial power-up, a POR delay occurs to permit voltage levels to stabilize. Subsequent reconfigurations do not incur this delay.

Table 11 lists the timing parameters when using EPC1, EPC1064, EPC1064V, EPC1213, and EPC1441 devices when configuring the FLEX 8000 device.

**Table 11. FLEX 8000 Device Configuration Parameters Using EPC1, EPC1064, EPC1064V, EPC1213, and EPC1441 Devices**

Symbol	Parameter	EPC1064V		EPC1064 and EPC1213		EPC1 and EPC1441		Unit
		Min	Max	Min	Max	Min	Max	
$t_{OE\bar{Z}X}$	OE high to DATA output enabled	—	75	—	50	—	50	ns
$t_{CS\bar{Z}X}$	$\bar{n}CS$ low to DATA output enabled	—	75	—	50	—	50	ns
$t_{CS\bar{Z}Z}$	$\bar{n}CS$ high to DATA output disabled	—	75	—	50	—	50	ns
$t_{C\bar{S}S}$	$\bar{n}CS$ low setup time to first DCLK rising edge	150	—	100	—	50	—	ns
$t_{C\bar{S}H}$	$\bar{n}CS$ low hold time after DCLK rising edge	0	—	0	—	0	—	ns
$t_{D\bar{S}U}$	Data setup time before rising edge on DCLK	75	—	50	—	50	—	ns
$t_{D\bar{H}}$	Data hold time after rising edge on DCLK	0	—	0	—	0	—	ns
$t_{C\bar{O}}$	DCLK to DATA out delay	—	100	—	75	—	75	ns
$t_{C\bar{K}}$	Clock period	240	—	160	—	100	—	ns
$f_{C\bar{K}}$	Clock frequency	—	4	—	6	—	8	MHz
$t_{C\bar{L}}$	DCLK low time	120	—	80	—	50	—	ns
$t_{C\bar{H}}$	DCLK high time	120	—	80	—	50	—	ns
$t_{X\bar{Z}}$	OE low or $\bar{n}CS$ high to DATA output disabled	—	75	—	50	—	50	ns
$t_{O\bar{E}W}$	OE pulse width to guarantee counter reset	150	—	100	—	100	—	ns
$t_{C\bar{A}S\bar{C}}$	Last DCLK + 1 to $\bar{n}CASC$ low delay	—	90	—	60	—	50	ns
$t_{C\bar{K}X\bar{Z}}$	Last DCLK + 1 to DATA tri-state delay	—	75	—	50	—	50	ns
$t_{C\bar{E}O\bar{U}T}$	$\bar{n}CS$ high to $\bar{n}CASC$ high delay	—	150	—	100	—	100	ns

## Operating Conditions

Table 12 through Table 19 list information about absolute maximum ratings, recommended operating conditions, DC operating conditions, and capacitance for configuration devices.

**Table 12. Absolute Maximum Ratings <sup>(1)</sup>**

Symbol	Parameter	Conditions	Min	Max	Unit
$V_{CC}$	Supply voltage	With respect to GND <sup>(2)</sup>	-2.0	7.0	V
$V_I$	DC input voltage	With respect to GND <sup>(2)</sup>	-2.0	7.0	V
$I_{MAX}$	DC $V_{CC}$ or GND current	—	—	50	mA
$I_{OUT}$	DC output current, per pin	—	-25	25	mA
$P_D$	Power dissipation	—	—	250	mW
$T_{STG}$	Storage temperature	No bias	-65	150	° C
$T_{AMB}$	Ambient temperature	Under bias	-65	135	° C
$T_J$	Junction temperature	Under bias	—	135	° C

**Table 13. Recommended Operating Conditions**

Symbol	Parameter	Conditions	Min	Max	Unit
$V_{CC}$	Supply voltage for 5.0-V operation	<sup>(3)</sup> , <sup>(4)</sup>	4.75 (4.50)	5.25 (5.50)	V
	Supply voltage for 3.3-V operation	<sup>(3)</sup> , <sup>(4)</sup>	3.0 (3.0)	3.6 (3.6)	V
$V_I$	Input voltage	With respect to GND	-0.3	$V_{CC} + 0.3$ <sup>(5)</sup>	V
$V_O$	Output voltage	—	0	$V_{CC}$	V
$T_A$	Operating temperature	For commercial use	0	70	° C
		For industrial use	-40	85	° C
$t_R$	Input rise time	—	—	20	ns
$t_F$	Input fall time	—	—	20	ns

**Table 14. DC Operating Conditions**

Symbol	Parameter	Conditions	Min	Max	Unit
$V_{IH}$	High-level input voltage	—	2.0	$V_{CC} + 0.3$ <sup>(5)</sup>	V
$V_{IL}$	Low-level input voltage	—	-0.3	0.8	V
$V_{OH}$	5.0-V mode high-level TTL output voltage	$I_{OH} = -4$ mA DC <sup>(6)</sup>	2.4	—	V
	3.3-V mode high-level CMOS output voltage	$I_{OH} = -0.1$ mA DC <sup>(6)</sup>	$V_{CC} - 0.2$	—	V
$V_{OL}$	Low-level output voltage	$I_{OL} = 4$ mA DC <sup>(6)</sup>	—	0.4	V
$I_I$	Input leakage current	$V_I = V_{CC}$ or GND	-10	10	μA
$I_{OZ}$	Tri-state output off-state current	$V_O = V_{CC}$ or GND	-10	10	μA

**Table 15. EPC1064, EPC1064V, and EPC1213 Devices  $I_{CC}$  Supply Current Values**

Symbol	Parameter	Conditions	Min	Typ	Max	Unit
$I_{CC0}$	$V_{CC}$ supply current (standby)	—	—	100	200	$\mu\text{A}$
$I_{CC1}$	$V_{CC}$ supply current (during configuration)	—	—	10	50	mA

**Table 16. EPC2 Device Values**

Symbol	Parameter	Conditions	Min	Typ	Max	Unit
$I_{CC0}$	$V_{CC}$ supply current (standby)	$V_{CC} = 5.0\text{ V}$ or $3.3\text{ V}$	—	50	100	$\mu\text{A}$
$I_{CC1}$	$V_{CC}$ supply current (during configuration)	$V_{CC} = 5.0\text{ V}$ or $3.3\text{ V}$	—	18	50	mA
$R_{CONF}$	Configuration pins	Internal pull up ( $O_E$ , $nCS$ , $nINIT\_CONF$ )	—	1	—	$k\Omega$

**Table 17. EPC1 Device  $I_{CC}$  Supply Current Values**

Symbol	Parameter	Conditions	Min	Typ	Max	Unit
$I_{CC0}$	$V_{CC}$ supply current (standby)	—	—	50	100	$\mu\text{A}$
$I_{CC1}$	$V_{CC}$ supply current (during configuration)	$V_{CC} = 5.0\text{ V}$	—	30	50	mA
		$V_{CC} = 3.3\text{ V}$	—	10	16.5	mA

**Table 18. EPC1441 Device  $I_{CC}$  Supply Current Values**

Symbol	Parameter	Conditions	Min	Typ	Max	Unit
$I_{CC0}$	$V_{CC}$ supply current (standby)	—	—	30	60	$\mu\text{A}$
$I_{CC1}$	$V_{CC}$ supply current (during configuration)	$V_{CC} = 5.0\text{ V}$	—	15	30	mA
$I_{CC1}$	$V_{CC}$ supply current (during configuration)	$V_{CC} = 3.3\text{ V}$	—	5	10	mA

**Table 19. Capacitance <sup>(7)</sup>**

Symbol	Parameter	Conditions	Min	Max	Unit
$C_{IN}$	Input pin capacitance	$V_{IN} = 0\text{ V}$ , $f = 1.0\text{ MHz}$	—	10	pF
$C_{OUT}$	Output pin capacitance	$V_{OUT} = 0\text{ V}$ , $f = 1.0\text{ MHz}$	—	10	pF

**Notes to Table 12 through Table 19:**

- (1) For more information, refer to the [Operating Requirements for Altera Devices Datasheet](#).
- (2) The minimum DC input is  $-0.3\text{ V}$ . During transitions, the inputs may undershoot to  $-2.0\text{ V}$  or overshoot to  $7.0\text{ V}$  for input currents less than  $100\text{ mA}$  and periods shorter than  $20\text{ ns}$  under no-load conditions.
- (3) Numbers in parentheses are for industrial temperature range devices.
- (4) Maximum  $V_{CC}$  rise time is  $100\text{ ms}$ .
- (5) Certain EPC2 device pins are driven to  $5.75\text{ V}$  when operated with a  $3.3\text{-V } V_{CC}$ . For more information, refer to [Table 4 on page 11](#).
- (6) The  $I_{OH}$  parameter refers to high-level TTL or CMOS output current and the  $I_{OL}$  parameter refers to low-level TTL or CMOS output current.
- (7) Capacitance is sample tested only.

## Pin Information

Table 20 lists the pin functions of the EPC1, EPC2, and EPC1441 devices during device configuration.

 For more information about pin information of EPC devices, refer to the [Enhanced Configuration \(EPC\) Devices Datasheet](#).

 For more information about pin information of EPCS devices, refer to the [Serial Configuration \(EPCS\) Devices Datasheet](#).

**Table 20. EPC1, EPC2, and EPC1441 Device Pin Functions During Configuration (Part 1 of 3)**

Pin Name	Pin Number			Pin Type	Description
	8-Pin PDIP <sup>(1)</sup>	20-Pin PLCC	32-Pin TQFP <sup>(2)</sup>		
DATA	1	2	31	Output	Serial data output. The DATA pin connects to the DATA0 pin of the FPGA. DATA is latched into the FPGA on the rising edge of DCLK.  The DATA pin is tri-stated before configuration and when the nCS pin is high. After configuration, the EPC2 device drives DATA high, while the EPC1 and EPC1441 device tri-state DATA.
DCLK	2	4	2	Bidirectional	Clock output when configuring with a single configuration device or when the configuration device is the first (master) device in a chain. Clock input for the next (slave) configuration devices in a chain. The DCLK pin connects to the DCLK pin of the FPGA.  Rising edges on DCLK increment the internal address counter and present the next bit of data on the DATA pin. The counter is incremented only if the OE input is held high, the nCS input is held low, and all configuration data has not been transferred to the target device.  After configuration or when OE is low, the EPC1, EPC2 and EPC1441 device drive DCLK low.
OE	3	8	7	Open-drain bidirectional	Output enable (active high) and reset (active low). The OE pin connects to the nSTATUS pin of the FPGA.  A low logic level resets the address counter. A high logic level enables DATA and the address counter to count. If this pin is low (reset) during configuration, the internal oscillator becomes inactive and DCLK drives low. For more information, refer to <a href="#">“Error Detection Circuitry” on page 9</a> .  The OE pin has an internal programmable 1-kΩ resistor in EPC2 devices. If internal pull-up resistors are used, do not use external pull-up resistors on these pins. You can disable the internal pull-up resistors through the <b>Disable nCS and OE pull-ups on configuration device</b> option.

Table 20. EPC1, EPC2, and EPC1441 Device Pin Functions During Configuration (Part 2 of 3)

Pin Name	Pin Number			Pin Type	Description
	8-Pin PDIP <sup>(1)</sup>	20-Pin PLCC	32-Pin TQFP <sup>(2)</sup>		
<i>n</i> CS	4	9	10	Input	<p>Chip select input (active low). The <i>n</i>CS pin connects to the CONF_DONE pin of the FPGA.</p> <p>A low input allows DCLK to increment the address counter and enables DATA to drive out. If the EPC1 or EPC2 device is reset (OE pulled low) while <i>n</i>CS is low, the device initializes as the master device in a configuration chain. If the EPC1 or EPC2 device is reset (OE pulled low) while <i>n</i>CS is high, the device initializes as a slave device in the chain.</p> <p>The <i>n</i>CS pin has an internal programmable 1-kΩ resistor in EPC2 devices. If internal pull-up resistors are used, do not use external pull-up resistors on these pins. You can disable the internal pull-up resistors through the <b>Disable <i>n</i>CS and OE pull-ups on configuration device</b> option.</p>
<i>n</i> CASC	6	12	15	Output	<p>Cascade select output (active low).</p> <p>This output goes low when the address counter has reached its maximum value. When the address counter has reached its maximum value, the configuration device has sent all its configuration data to the FPGA. In a chain of EPC1 or EPC2 devices, the <i>n</i>CASC pin of one device is connected to the <i>n</i>CS pin of the next device, which permits DCLK to clock data from the next EPC1 or EPC2 device in the chain. For single EPC1 or EPC2 device and the last device in the chain, <i>n</i>CASC is left floating.</p> <p>This pin is only available in EPC1 and EPC2 devices, which support data cascading.</p>
<i>n</i> INIT_CONF	N/A	13	16	Open-Drain Output	<p>Allows the INIT_CONF JTAG instruction to initiate configuration. The <i>n</i>INIT_CONF pin connects to the <i>n</i>CONFIG pin of the FPGA.</p> <p>If multiple EPC2 devices are used to configure an FPGA, the <i>n</i>INIT_CONF of the first EPC2 device pin is tied to the FPGA's <i>n</i>CONFIG pin, while subsequent devices' <i>n</i>INIT_CONF pins are left floating.</p> <p>The INIT_CONF pin has an internal 1-kΩ pull-up resistor that is always active in EPC2 devices.</p> <p>This pin is only available in EPC2 devices.</p>
TDI	N/A	11	13	Input	<p>JTAG data input pin. Connect this pin to V<sub>CC</sub> if the JTAG circuitry is not used.</p> <p>This pin is only available in EPC2 devices.</p>
TDO	N/A	1	28	Output	<p>JTAG data output pin. Do not connect this pin if the JTAG circuitry is not used.</p> <p>This pin is only available in EPC2 devices.</p>
TMS	N/A	19	25	Input	<p>JTAG mode select pin. Connect this pin to V<sub>CC</sub> if the JTAG circuitry is not used.</p> <p>This pin is only available in EPC2 devices.</p>

**Table 20. EPC1, EPC2, and EPC1441 Device Pin Functions During Configuration (Part 3 of 3)**

Pin Name	Pin Number			Pin Type	Description
	8-Pin PDIP <sup>(1)</sup>	20-Pin PLCC	32-Pin TQFP <sup>(2)</sup>		
TCK	N/A	3	32	Input	JTAG clock pin. Connect this pin to GND if the JTAG circuitry is not used. This pin is only available in EPC2 devices.
VCCSEL	N/A	5	3	Input	Mode select for $V_{CC}$ supply. $V_{CCSEL}$ must be connected to GND if the device uses a 5.0-V power supply ( $V_{CC} = 5.0$ V). $V_{CCSEL}$ must be connected to $V_{CC}$ if the device uses a 3.3-V power supply ( $V_{CC} = 3.3$ V). This pin is only available in EPC2 devices.
VPPSEL	N/A	14	17	Input	Mode select for $V_{PP}$ supply. $V_{PPSEL}$ must be connected to GND if $V_{PP}$ uses a 5.0-V power supply ( $V_{PP} = 5.0$ V). $V_{PPSEL}$ must be connected to $V_{CC}$ if $V_{PP}$ uses a 3.3-V power supply ( $V_{PP} = 3.3$ V). This pin is only available in EPC2 devices.
VPP	N/A	18	23	Power	Programming power pin. For the EPC2 device, this pin is normally tied to $V_{CC}$ . If the $V_{CC}$ of the EPC2 device is 3.3 V, tie $V_{PP}$ to 5.0 V to improve ISP time. For EPC1 and EPC1441 devices, $V_{PP}$ must be tied to $V_{CC}$ . This pin is only available in EPC2 devices.
VCC	7, 8	20	27	Power	Power pin.
GND	5	10	12	Ground	Ground pin. Place a 0.2- $\mu$ F decoupling capacitor between the VCC and GND pins.

**Notes to Table 20:**

- (1) This package is available for EPC1 and EPC1441 devices only.  
(2) This package is available for EPC2 and EPC1441 devices only.

# Package

Figure 6 and Figure 7 show the configuration device package pin-outs.

**Figure 6. EPC1, EPC1064, EPC1064V, EPC1213, and EPC1441 Package Pin-Out Diagrams <sup>(1)</sup>**

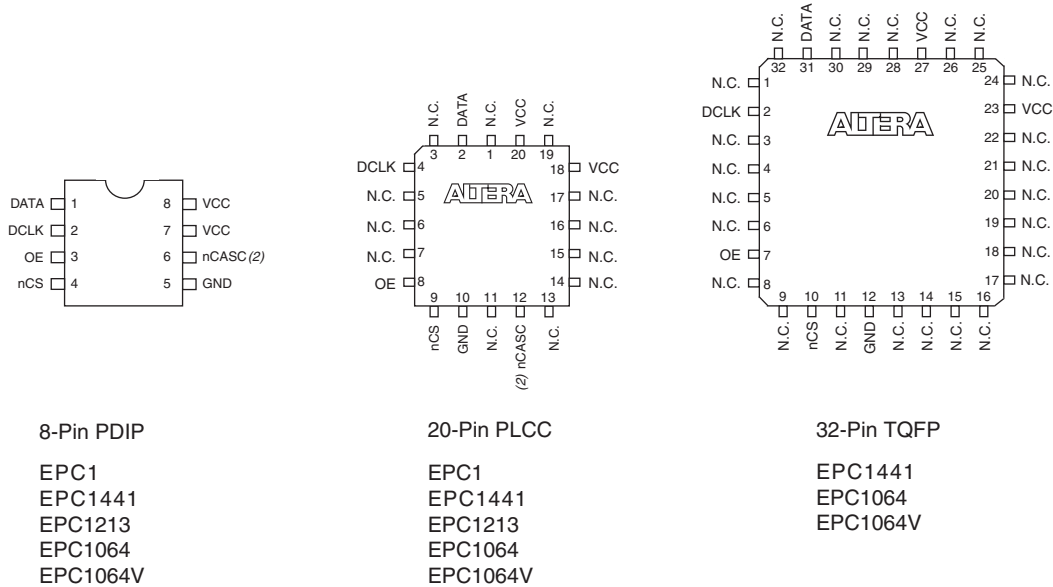

**Notes to Figure 6:**

- (1) EPC1 and EPC1441 devices are one-time programmable devices. ISP is not available in these devices.
- (2) The nCASC pin is available on EPC1 devices, which allows them to be cascaded. For EPC1441 devices, nCASC is a reserved pin and should be left unconnected.

**Figure 7. EPC2 Package Pin-Out Diagrams**

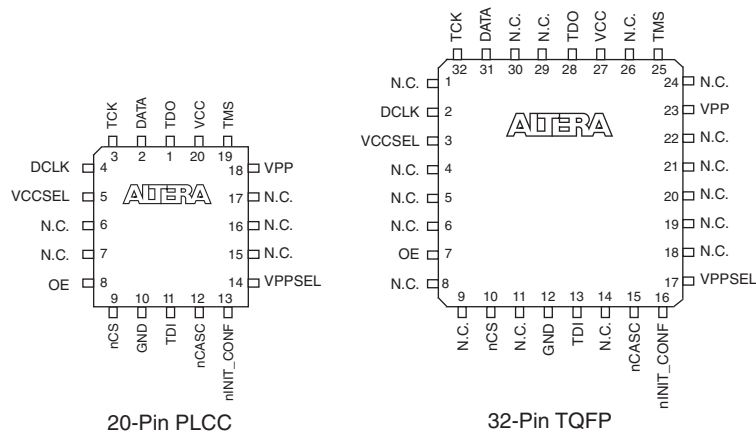

For more information about package outlines and drawings, refer to the [Package and Thermal Resistance](#) page.

## Ordering Codes

Table 21 lists the ordering codes for the EPC1, EPC2, and EPC1441 configuration devices.

**Table 21. Configuration Device Ordering Codes**

Device	Package	Temperature	Ordering Code
EPC1	20-pin PLCC	Commercial	EPC1LC20
EPC1	20-pin PLCC	Industrial	EPC1LI20
EPC1	8-pin PDIP	Commercial	EPC1PC8
EPC1	8-pin PDIP	Industrial	EPC1PI8
EPC2	32-pin TQFP	Commercial	EPC2TC32
EPC2	32-pin TQFP	Industrial	EPC2TI32
EPC2	20-pin PLCC	Commercial	EPC2LC20
EPC2	20-pin PLCC	Industrial	EPC2LI20
EPC1441	32-pin TQFP	Commercial	EPC1441TC32
EPC1441	32-pin TQFP	Industrial	EPC1441TI32
EPC1441	20-pin PLCC	Commercial	EPC1441LC20
EPC1441	20-pin PLCC	Industrial	EPC1441LI20
EPC1441	8-pin PDIP	Commercial	EPC1441PC8
EPC1441	8-pin PDIP	Industrial	EPC1441PI8

## Document Revision History

Table 22 lists the revision history for this document.

**Table 22. Document Revision History**

Date	Version	Changes
January 2012	3.0	Minor text edits.
December 2009	2.4	<ul style="list-style-type: none"> <li>■ Updated “Features” section.</li> <li>■ Removed “Referenced Documents” section.</li> </ul>
October 2008	2.3	<ul style="list-style-type: none"> <li>■ Updated “Features” and “IEEE Std. 1149.1 (JTAG) Boundary-Scan Testing” sections.</li> <li>■ Updated Table 5–2 and Table 5–16.</li> <li>■ Added “Referenced Documents” section.</li> <li>■ Updated new document format.</li> </ul>
April 2007	2.2	Added document revision history.
July 2004	2.0	Added Stratix II and Cyclone II device information throughout chapter.
September 2003	1.0	Initial Release.

