

# SN54221, SN54LS221, SN74221, SN74LS221 DUAL MONOSTABLE MULTIVIBRATORS WITH SCHMITT-TRIGGER INPUTS

SDLS213B – DECEMBER 1983 – REVISED NOVEMBER 2004

- Dual Versions of Highly Stable SN54121 and SN74121 One Shots
- SN54221 and SN74221 Demonstrate Electrical and Switching Characteristics That Are Virtually Identical to the SN54121 and SN74121 One Shots
- Pinout Is Identical to the SN54123, SN74123, SN54LS123, and SN74LS123
- Overriding Clear Terminates Output Pulse

TYPE	MAXIMUM OUTPUT PULSE LENGTH(S)
SN54221	21
SN74221	28
SN54LS221	49
SN74LS221	70

## description/ordering information

The '221 and 'LS221 devices are dual multivibrators with performance characteristics virtually identical to those of the '121 devices. Each multivibrator features a negative-transition-triggered input and a positive-transition-triggered input, either of which can be used as an inhibit input.

SN54221, SN54LS221 . . . J PACKAGE  
SN74221 . . . N PACKAGE  
SN74LS221 . . . D, DB, N, OR NS PACKAGE  
(TOP VIEW)

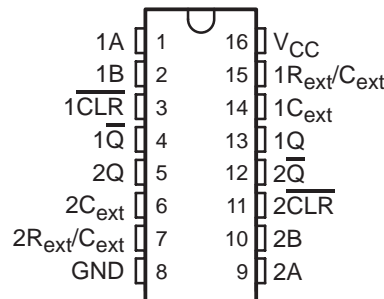

SN54LS221 . . . FK PACKAGE  
(TOP VIEW)

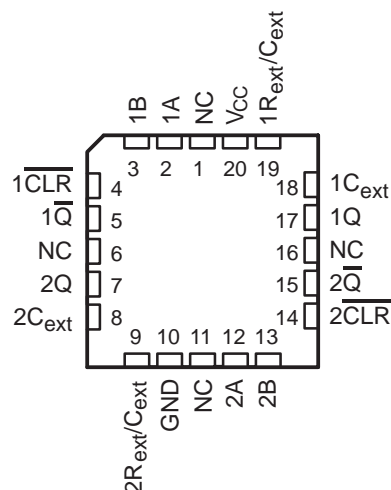

NC – No internal connection

## ORDERING INFORMATION

T <sub>A</sub>	PACKAGE†		ORDERABLE PART NUMBER	TOP-SIDE MARKING
0°C to 70°C	PDIP – N	Tube	SN74221N	SN74221N
			SN74LS221N	SN74LS221N
	SOIC – D	Tube	SN74LS221D	LS221
			Tape and reel	
		SOP – NS	Tape and reel	SN74LS221NSR
SSOP – DB	Tape and reel	SN74LS221DBR	LS221	
–55°C to 125°C	CDIP – J	Tube	SNJ54221J	SNJ54221J
			SNJ54LS221J	SNJ54LS221J
	LCCC – FK	Tube	SNJ54LS221FK	SNJ54LS221FK

† Package drawings, standard packing quantities, thermal data, symbolization, and PCB design guidelines are available at [www.ti.com/sc/package](http://www.ti.com/sc/package).



Please be aware that an important notice concerning availability, standard warranty, and use in critical applications of Texas Instruments semiconductor products and disclaimers thereto appears at the end of this data sheet.

PRODUCTION DATA information is current as of publication date. Products conform to specifications per the terms of Texas Instruments standard warranty. Production processing does not necessarily include testing of all parameters.

 **TEXAS  
INSTRUMENTS**

POST OFFICE BOX 655303 • DALLAS, TEXAS 75265

Copyright © 2004, Texas Instruments Incorporated  
On products compliant to MIL-PRF-38535, all parameters are tested unless otherwise noted. On all other products, production processing does not necessarily include testing of all parameters.

# SN54221, SN54LS221, SN74221, SN74LS221 DUAL MONOSTABLE MULTIVIBRATORS WITH SCHMITT-TRIGGER INPUTS

SDLS213B – DECEMBER 1983 – REVISED NOVEMBER 2004

## description/ordering information (continued)

Pulse triggering occurs at a particular voltage level and is not directly related to the transition time of the input pulse. Schmitt-trigger input circuitry (TTL hysteresis) for B input allows jitter-free triggering from inputs with transition at rates as slow as 1 V/s, providing the circuit with excellent noise immunity, typically of 1.2 V. A high immunity to  $V_{CC}$  noise, typically of 1.5 V, also is provided by internal latching circuitry.

Once fired, the outputs are independent of further transitions of the A and B inputs and are a function of the timing components, or the output pulses can be terminated by the overriding clear. Input pulses can be of any duration relative to the output pulse. Output pulse length can be varied from 35 ns to the maximum by choosing appropriate timing components. With  $R_{ext} = 2\text{ k}\Omega$  and  $C_{ext} = 0$ , an output pulse typically of 30 ns is achieved that can be used as a dc-triggered reset signal. Output rise and fall times are TTL compatible and independent of pulse length. Typical triggering and clearing sequences are shown as a part of the switching characteristics waveforms.

Pulse-width stability is achieved through internal compensation and is virtually independent of  $V_{CC}$  and temperature. In most applications, pulse stability is limited only by the accuracy of external timing components.

Jitter-free operation is maintained over the full temperature and  $V_{CC}$  ranges for more than six decades of timing capacitance (10 pF to 10  $\mu\text{F}$ ) and more than one decade of timing resistance (2 k $\Omega$  to 30 k $\Omega$  for the SN54221, 2 k $\Omega$  to 40 k $\Omega$  for the SN74221, 2 k $\Omega$  to 70 k $\Omega$  for the SN54LS221, and 2 k $\Omega$  to 100 k $\Omega$  for the SN74LS221). Throughout these ranges, pulse width is defined by the relationship:  $t_w(\text{out}) = C_{ext}R_{ext} \ln 2 \approx 0.7 C_{ext}R_{ext}$ . In circuits where pulse cutoff is not critical, timing capacitance up to 1000  $\mu\text{F}$  and timing resistance as low as 1.4 k $\Omega$  can be used. Also, the range of jitter-free output pulse widths is extended if  $V_{CC}$  is held to 5 V and free-air temperature is 25°C. Duty cycles as high as 90% are achieved when using maximum recommended  $R_T$ . Higher duty cycles are available if a certain amount of pulse-width jitter is allowed.

The variance in output pulse width from device to device typically is less than  $\pm 0.5\%$  for given external timing components. An example of this distribution for the '221 is shown in Figure 3. Variations in output pulse width versus supply voltage and temperature for the '221 are shown in Figures 4 and 5, respectively.

Pin assignments for these devices are identical to those of the SN54123/SN74123 or SN54LS123/SN74LS123 so that the '221 or 'LS221 devices can be substituted for those products in systems not using the retrigger by merely changing the value of  $R_{ext}$  and/or  $C_{ext}$ ; however, the polarity of the capacitor must be changed.

**FUNCTION TABLE**  
(each monostable multivibrator)

INPUTS			OUTPUTS	
$\overline{\text{CLR}}$	A	B	Q	$\overline{\text{Q}}$
L	X	X	L	H
X	H	X	L	H
X	X	L	L	H
H	L	$\uparrow$		
H	$\downarrow$	H		
$\uparrow\ddagger$	L	H		

† Pulsed-output patterns are tested during AC switching at 25°C with  $R_{ext} = 2\text{ k}\Omega$ , and  $C_{ext} = 80\text{ pF}$ .

‡ This condition is true only if the output of the latch formed by the two NAND gates has been conditioned to the logic 1 state prior to  $\overline{\text{CLR}}$  going high. This latch is conditioned by taking either A high or B low while  $\overline{\text{CLR}}$  is inactive (high).



**SN54221, SN54LS221, SN74221, SN74LS221**  
**DUAL MONOSTABLE MULTIVIBRATORS**  
**WITH SCHMITT-TRIGGER INPUTS**

SDLS213B – DECEMBER 1983 – REVISED NOVEMBER 2004

**timing component connections**

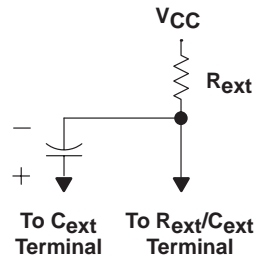

NOTE: Due to the internal circuit, the  $R_{ext}/C_{ext}$  terminal never is more positive than the  $C_{ext}$  terminal.

# SN54221, SN54LS221, SN74221, SN74LS221 DUAL MONOSTABLE MULTIVIBRATORS WITH SCHMITT-TRIGGER INPUTS

SDLS213B – DECEMBER 1983 – REVISED NOVEMBER 2004

## schematics of inputs and outputs

SN54/74221

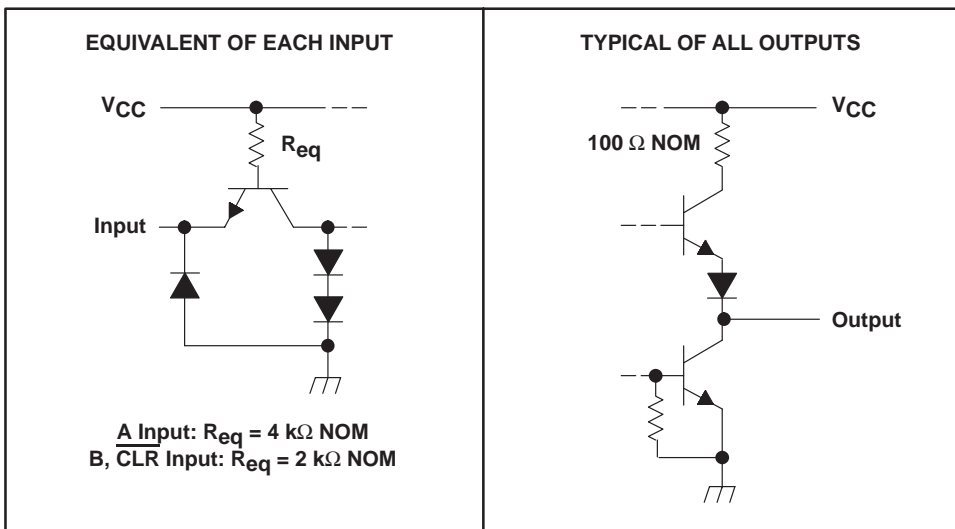

SN54/74LS221

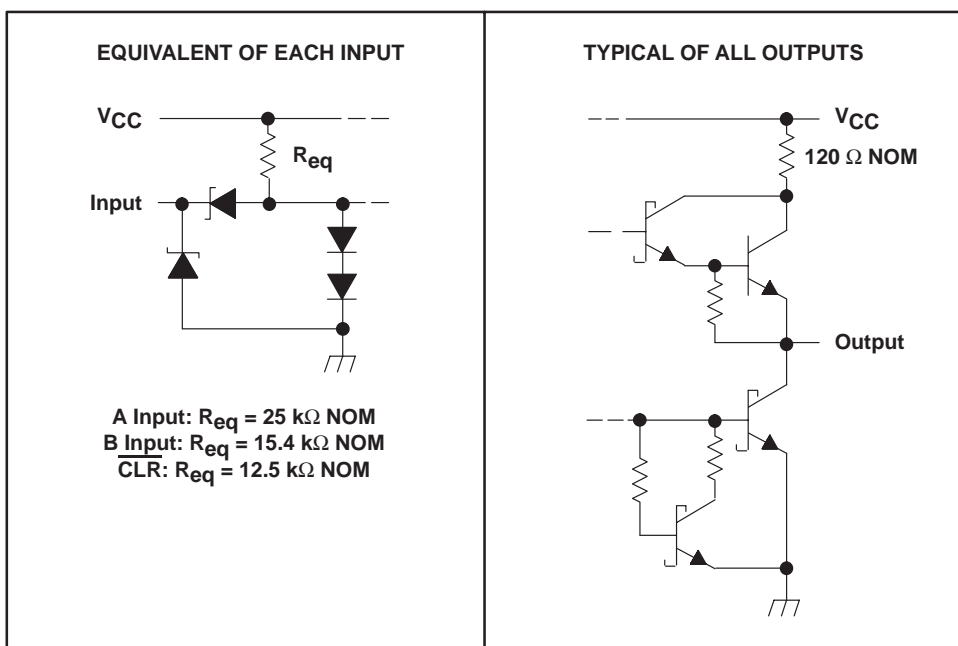

# SN54221, SN54LS221, SN74221, SN74LS221 DUAL MONOSTABLE MULTIVIBRATORS WITH SCHMITT-TRIGGER INPUTS

SDLS213B – DECEMBER 1983 – REVISED NOVEMBER 2004

## absolute maximum ratings over operating free-air temperature range (unless otherwise noted)†

Supply voltage range, $V_{CC}$ .....	7 V
Input voltage range, $V_I$ (see Note 1): 'LS221 .....	7 V
'221 .....	5.5 V
Package thermal impedance, $\theta_{JA}$ (see Note 2): D package .....	73°C/W
DB package .....	82°C/W
N package .....	67°C/W
NS package .....	64°C/W
Storage temperature range, $T_{stg}$ .....	–65°C to 150°C

† Stresses beyond those listed under “absolute maximum ratings” may cause permanent damage to the device. These are stress ratings only, and functional operation of the device at these or any other conditions beyond those indicated under “recommended operating conditions” is not implied. Exposure to absolute-maximum-rated conditions for extended periods may affect device reliability.

- NOTES: 1. The input and output negative-voltage ratings may be exceeded if the input and output clamp-current ratings are observed.  
2. The package thermal impedance is calculated in accordance with JESD 51-7.

## recommended operating conditions (see Note 3)

		SN54221			SN74221			UNIT
		MIN	NOM	MAX	MIN	NOM	MAX	
$V_{CC}$	Supply voltage	4.5	5	5.5	4.75	5	5.25	V
$I_{OH}$	High-level output current			–800			–800	$\mu$ A
$I_{OL}$	Low-level output current			16			16	mA
$\Delta v/\Delta t$	Rise or fall of input pulse rate	B input		1*	1			V/s
		A input		1*	1			V/ $\mu$ s
$T_A$	Operating free-air temperature	–55		125	0		70	°C

\* On products compliant to MIL-PRF-38535, this parameter is not production tested.

NOTE 3: All unused inputs of the device must be held at  $V_{CC}$  or GND to ensure proper device operation. Refer to the TI application report, *Implications of Slow or Floating CMOS Inputs*, literature number SCBA004.



# SN54221, SN54LS221, SN74221, SN74LS221 DUAL MONOSTABLE MULTIVIBRATORS WITH SCHMITT-TRIGGER INPUTS

SDLS213B – DECEMBER 1983 – REVISED NOVEMBER 2004

electrical characteristics over recommended operating free-air temperature range (unless otherwise noted)

PARAMETER		TEST CONDITIONS†	SN54221			SN74221			UNIT
			MIN	TYP‡	MAX	MIN	TYP‡	MAX	
$V_{T+}$	Positive-going threshold voltage, B input	$V_{CC} = \text{MIN}$	1.55		2*	1.55		2	V
$V_{T-}$	Negative-going threshold voltage, B input	$V_{CC} = \text{MIN}$	0.8*	1.35		0.8	1.35		V
$V_{IK}$		$V_{CC} = \text{MIN}$ , $I_I = -12 \text{ mA}$			-1.5			-1.5	V
$V_{OH}$		$V_{CC} = \text{MIN}$ , $I_{OH} = -800 \mu\text{A}$	2.4	3.4		2.4	3.4		V
$V_{OL}$		$V_{CC} = \text{MIN}$ , $I_{OL} = 16 \text{ mA}$	0.2	0.4		0.2	0.4		V
$I_I$		$V_{CC} = \text{MAX}$ , $V_I = 5.5 \text{ V}$			1			1	mA
$I_{IH}$	A input	$V_{CC} = \text{MAX}$ , $V_I = 2.4 \text{ V}$			40			40	$\mu\text{A}$
	$\overline{\text{CLR}}$ , B input				80			80	
$I_{IL}$	A input	$V_{CC} = \text{MAX}$ , $V_I = 0.4 \text{ V}$			-1.6			-1.6	mA
	$\overline{\text{CLR}}$ , B input				-3.2			-3.2	
$I_{OS}^{\S}$		$V_{CC} = \text{MAX}$	-20		-55	-18		-55	mA
$I_{CC}$	Quiescent	$V_{CC} = \text{MAX}$	26		50*	26		50	mA
	Triggered		46		80*	46		80	

\* On products compliant to MIL-PRF-38535, this parameter is not production tested.

† For conditions shown as MIN or MAX, use the appropriate value specified under recommended operating conditions.

‡ All typical values are at  $V_{CC} = 5 \text{ V}$ ,  $T_A = 25^\circ\text{C}$ .

§ Not more than one output should be shorted at a time, and the duration of the short circuit should not exceed one second.

## timing requirements over recommended ranges of supply voltage and operating free-air temperature

			SN54221		SN74221		UNIT
			MIN	MAX	MIN	MAX	
$t_w$	Pulse duration	A or B input	50		50		ns
		$\overline{\text{CLR}}$	20		20		
$t_{su}$	Setup time, inactive-state¶	$\overline{\text{CLR}}$	15		15		ns
$R_{ext}$	External timing resistance		1.4*	30*	1.4	40	k $\Omega$
$C_{ext}$	External timing capacitance		0*	1000*	0	1000	$\mu\text{F}$
	Output duty cycle	$R_{ext} = 2 \text{ k}\Omega$		67%		67%	
		$R_{ext} = \text{MAX } R_{ext}$		90%		90%	

\* On products compliant to MIL-PRF-38535, this parameter is not production tested.

¶ Inactive-state setup time also is referred to as recovery time.



# SN54221, SN54LS221, SN74221, SN74LS221 DUAL MONOSTABLE MULTIVIBRATORS WITH SCHMITT-TRIGGER INPUTS

SDLS213B – DECEMBER 1983 – REVISED NOVEMBER 2004

**switching characteristics  $V_{CC} = 5\text{ V}$ ,  $R_L = 400\ \Omega$ ,  $T_A = 25^\circ\text{C}$  (see Figures 1 and 2)**

PARAMETER	FROM (INPUT)	TO (OUTPUT)	TEST CONDITIONS	SN54221			SN74221			UNIT	
				MIN	TYP	MAX	MIN	TYP	MAX		
$t_{PLH}$	A	Q	$C_{ext} = 80\text{ pF}$ , $R_{ext} = 2\text{ k}\Omega$	45	70		45	70	ns		
	B			35	55		35	55			
$t_{PHL}$	A	$\overline{Q}$		50	80		50	80			
	B			40	65		40	65			
$t_{PHL}$	$\overline{CLR}$	Q		$C_{ext} = 80\text{ pF}$ , $R_{ext} = 2\text{ k}\Omega$	27			27			ns
$t_{PLH}$		$\overline{Q}$			40			40			
$t_w$	A or B	Q or $\overline{Q}$	$C_{ext} = 80\text{ pF}$ , $R_{ext} = 2\text{ k}\Omega$	70	110	150	70	110	150	ns	
			$C_{ext} = 0$ , $R_{ext} = 2\text{ k}\Omega$	17	30	50	17	30	50		
			$C_{ext} = 100\text{ pF}$ , $R_{ext} = 10\text{ k}\Omega$	650	700	750	650	700	750		
			$C_{ext} = 1\ \mu\text{F}$ , $R_{ext} = 10\text{ k}\Omega$	6.5*	7	7.5*	6.5	7	7.5		ms

\* On products compliant to MIL-PRF-38535, this parameter is not production tested.

### recommended operating conditions (see Note 4)

		SN54LS221			SN74LS221			UNIT
		MIN	NOM	MAX	MIN	NOM	MAX	
$V_{CC}$	Supply voltage	4.5	5	5.5	4.75	5	5.25	V
$I_{OH}$	High-level output current			-400			-400	$\mu\text{A}$
$I_{OL}$	Low-level output current			4			8	mA
$\Delta v/\Delta t$	Rise or fall of input pulse rate	B input	1*		1			V/s
		A input	1*		1			V/ $\mu\text{s}$
$T_A$	Operating free-air temperature	-55		125	0		70	$^\circ\text{C}$

\* On products compliant to MIL-PRF-38535, this parameter is not production tested.

NOTE 4: All unused inputs of the device must be held at  $V_{CC}$  or GND to ensure proper device operation. Refer to the TI application report, *Implications of Slow or Floating CMOS Inputs*, literature number SCBA004.

# SN54221, SN54LS221, SN74221, SN74LS221 DUAL MONOSTABLE MULTIVIBRATORS WITH SCHMITT-TRIGGER INPUTS

SDLS213B – DECEMBER 1983 – REVISED NOVEMBER 2004

electrical characteristics over recommended operating free-air temperature range (unless otherwise noted)

PARAMETER		TEST CONDITIONS†	SN54LS221			SN74LS221			UNIT
			MIN	TYP‡	MAX	MIN	TYP‡	MAX	
$V_{T+}$	Positive-going threshold voltage, B input	$V_{CC} = \text{MIN}$		1	2*		1	2	V
$V_{T-}$	Negative-going threshold voltage, B input	$V_{CC} = \text{MIN}$	0.7*	0.9		0.8	0.9		V
$V_{IK}$		$V_{CC} = \text{MIN}$ , $I_I = -18 \text{ mA}$			-1.5			-1.5	V
$V_{OH}$		$V_{CC} = \text{MIN}$ , $I_{OH} = -400 \mu\text{A}$	2.5	3.4		2.7	3.4		V
$V_{OL}$		$V_{CC} = \text{MIN}$	$I_{OL} = 4 \text{ mA}$		0.25	0.4	$I_{OL} = 4 \text{ mA}$		V
			$I_{OL} = 8 \text{ mA}$				$I_{OL} = 8 \text{ mA}$		
$I_I$		$V_{CC} = \text{MAX}$ , $V_I = 7 \text{ V}$			0.1			0.1	mA
$I_{IH}$		$V_{CC} = \text{MAX}$ , $V_I = 2.7 \text{ V}$			20			20	$\mu\text{A}$
$I_{IL}$	A input	$V_{CC} = \text{MAX}$ , $V_I = 0.4 \text{ V}$			-0.4			-0.4	mA
	$\overline{\text{CLR}}$ , B input				-0.8			-0.8	
$I_{OS}^{\S}$		$V_{CC} = \text{MAX}$	-20		-100	-20		-100	mA
$I_{CC}$	Quiescent	$V_{CC} = \text{MAX}$		4.7	11		4.7	11	mA
	Triggered			19	27*		19	27	

\* On products compliant to MIL-PRF-38535, this parameter is not production tested.

† For conditions shown as MIN or MAX, use the appropriate value specified under recommended operating conditions.

‡ All typical values are at  $V_{CC} = 5 \text{ V}$ ,  $T_A = 25^\circ\text{C}$ .

§ Not more than one output should be shorted at a time, and the duration of the short circuit should not exceed one second.

## timing requirements over recommended ranges of supply voltage and operating free-air temperature

			SN54LS221		SN74LS221		UNIT
			MIN	MAX	MIN	MAX	
$t_w$	Pulse duration	A or B	50		50		ns
		$\overline{\text{CLR}}$	40		40		
$t_{su}$	Setup time, inactive state¶	$\overline{\text{CLR}}$	15		15		ns
$R_{ext}$	External timing resistance		1.4*	70*	1.4	100	k $\Omega$
$C_{ext}$	External timing capacitance		0*	1000*	0	1000	$\mu\text{F}$
Output duty cycle		$R_T = 2 \text{ k}\Omega$		50%		50%	
		$R_T = \text{MAX } R_{ext}$		90%		90%	

\* On products compliant to MIL-PRF-38535, this parameter is not production tested.

¶ Inactive-state setup time also is referred to as recovery time.



**SN54221, SN54LS221, SN74221, SN74LS221**  
**DUAL MONOSTABLE MULTIVIBRATORS**  
**WITH SCHMITT-TRIGGER INPUTS**

SDLS213B – DECEMBER 1983 – REVISED NOVEMBER 2004

**switching characteristics  $V_{CC} = 5\text{ V}$ ,  $R_L = 2\text{ k}\Omega$ ,  $T_A = 25^\circ\text{ C}$  (see Figures 1 and 2)**

PARAMETER	FROM (INPUT)	TO (OUTPUT)	TEST CONDITIONS	SN54LS221			SN74LS221			UNIT		
				MIN	TYP	MAX	MIN	TYP	MAX			
$t_{PLH}$	A	Q	$C_{ext} = 80\text{ pF}$ , $R_{ext} = 2\text{ k}\Omega$	45	70		45	70	ns			
	B			35	55		35	55				
$t_{PHL}$	A	$\overline{Q}$		50	80		50	80				
	B			40	65		40	65				
$t_{PHL}$	$\overline{CLR}$	Q		$C_{ext} = 80\text{ pF}$ , $R_{ext} = 2\text{ k}\Omega$	35	55		35		55	ns	
$t_{PLH}$		$\overline{Q}$			44	65		44		65		
$t_w$	A or B	Q or $\overline{Q}$	$C_{ext} = 80\text{ pF}$ , $R_{ext} = 2\text{ k}\Omega$		70	120	150	70	120	150		ns
			$C_{ext} = 0$ , $R_{ext} = 2\text{ k}\Omega$		20	47	70	20	47	70		
			$C_{ext} = 100\text{ pF}$ , $R_{ext} = 10\text{ k}\Omega$	670	740	810	670	740	810			
			$C_{ext} = 1\text{ }\mu\text{F}$ , $R_{ext} = 10\text{ k}\Omega$	6*	6.9	7.5*	6	6.9	7.5	ms		

\* On products compliant to MIL-PRF-38535, this parameter is not production tested.

**SN54221, SN54LS221, SN74221, SN74LS221**  
**DUAL MONOSTABLE MULTIVIBRATORS**  
**WITH SCHMITT-TRIGGER INPUTS**

SDLS213B – DECEMBER 1983 – REVISED NOVEMBER 2004

**PARAMETER MEASUREMENT INFORMATION**

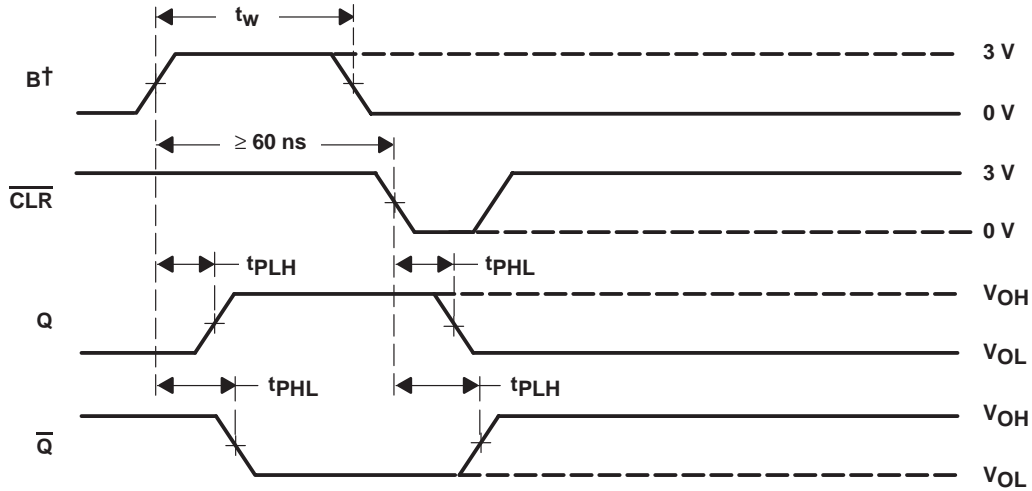

CONDITION 1: TRIGGER FROM B, THEN  $\overline{CLR}$

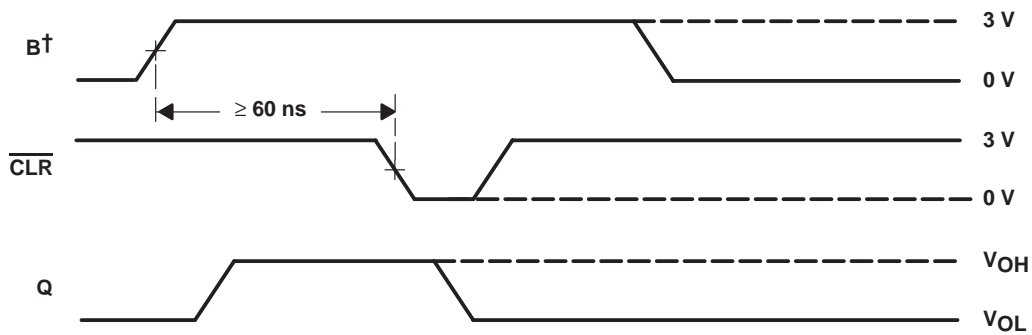

CONDITION 2: TRIGGER FROM B, THEN  $\overline{CLR}$

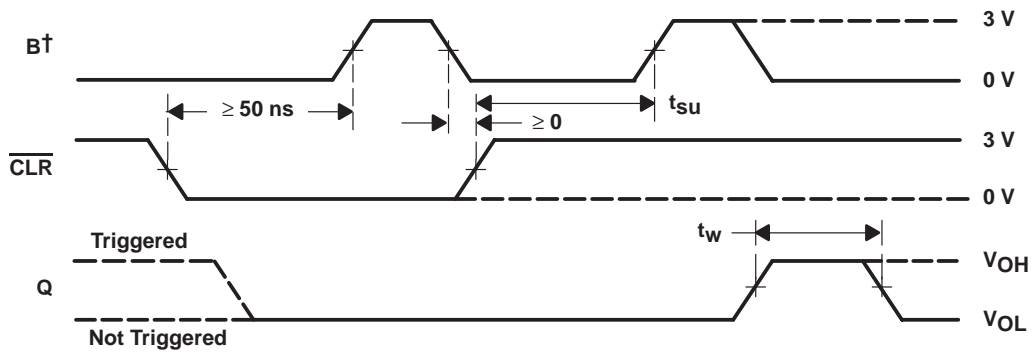

CONDITION 3:  $\overline{CLR}$  OVERRIDING B, THEN TRIGGER FROM B

† A is low.

Figure 1. Switching Characteristics



SN54221, SN54LS221, SN74221, SN74LS221  
 DUAL MONOSTABLE MULTIVIBRATORS  
 WITH SCHMITT-TRIGGER INPUTS

SDLS213B – DECEMBER 1983 – REVISED NOVEMBER 2004

PARAMETER MEASUREMENT INFORMATION

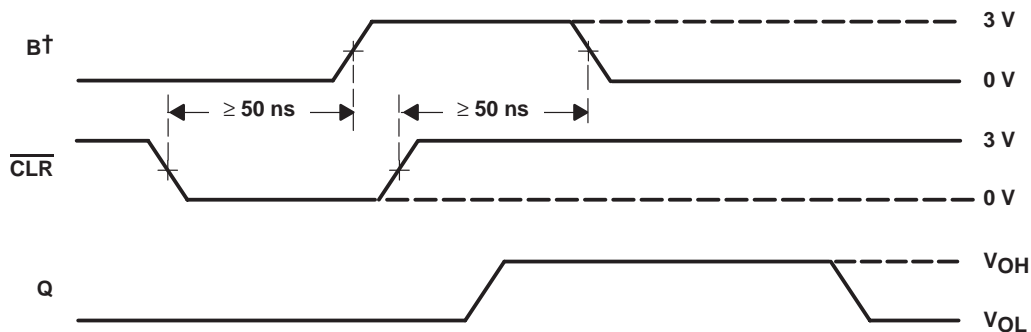

CONDITION 4: TRIGGERING FROM POSITIVE TRANSITION OF  $\overline{\text{CLR}}$

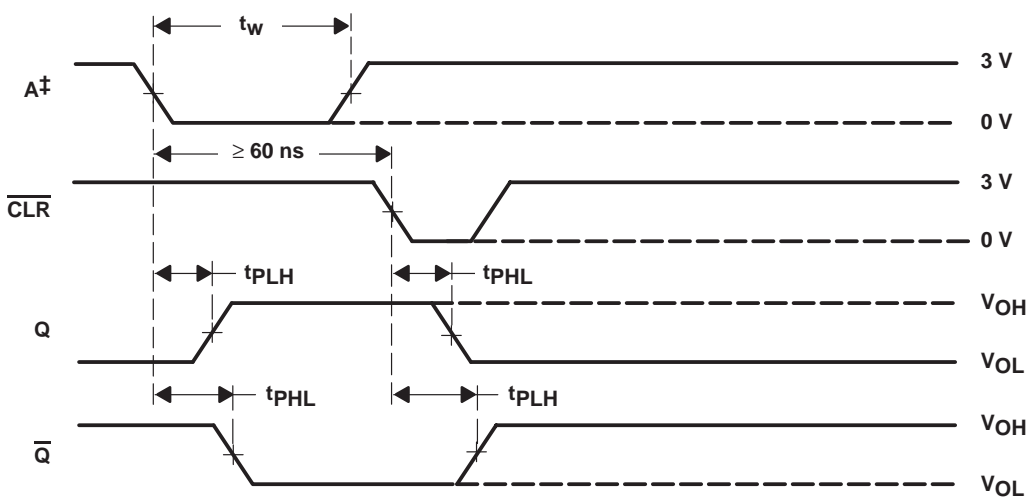

CONDITION 5: TRIGGER FROM A, THEN  $\overline{\text{CLR}}$

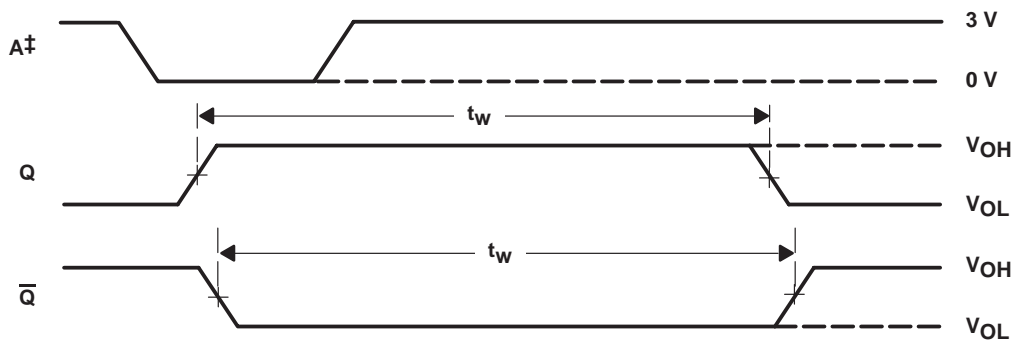

CONDITION 6: TRIGGER FROM A

† A is low.

‡ B and  $\overline{\text{CLR}}$  are high.

NOTES: A. Input pulses are supplied by generators having the following characteristics:  $\text{PRR} \leq 1 \text{ MHz}$ ,  $Z_O \approx 50\Omega$ ; for SN54/74221,  $t_r \leq 7 \text{ ns}$ ,  $t_f \leq 7 \text{ ns}$ , for SN54/74LS221,  $t_r \leq 15 \text{ ns}$ ,  $t_f \leq 6 \text{ ns}$ .

B. All measurements are made between the 1.5-V points of the indicated transitions for the SN54/74221 or between the 1.3-V points for the SN54/74LS221.

Figure 1. Switching Characteristics (Continued)



# SN54221, SN54LS221, SN74221, SN74LS221 DUAL MONOSTABLE MULTIVIBRATORS WITH SCHMITT-TRIGGER INPUTS

SDLS213B – DECEMBER 1983 – REVISED NOVEMBER 2004

## PARAMETER MEASUREMENT INFORMATION

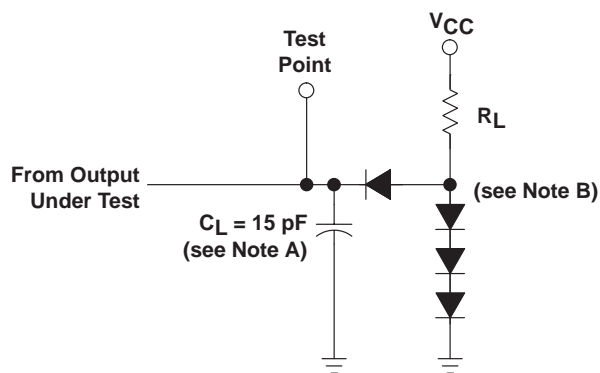

LOAD CIRCUIT FOR  
BI-STATE  
TOTEM-POLE OUTPUTS

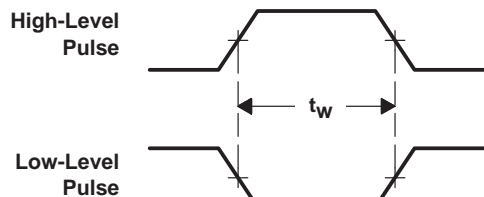

VOLTAGE WAVEFORMS  
PULSE DURATIONS

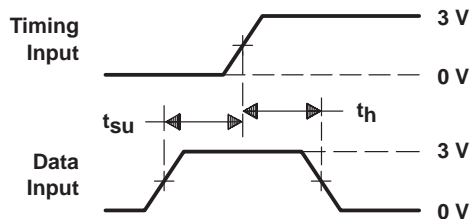

VOLTAGE WAVEFORMS  
SETUP AND HOLD TIMES

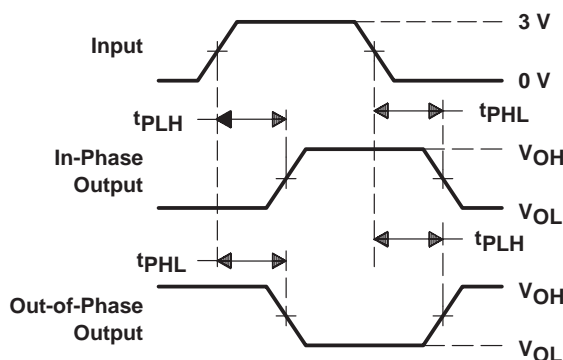

VOLTAGE WAVEFORMS  
PROPAGATION DELAY TIMES

- NOTES: A.  $C_L$  includes probe and jig capacitance.  
 B. All diodes are 1N3064 or equivalent.  
 C. In the examples above, the phase relationships between inputs and outputs have been chosen arbitrarily.  
 D. All input pulses are supplied by generators having the following characteristics:  $PRR \leq 1 \text{ MHz}$ ,  $Z_O \approx 50 \Omega$  and, for SN54/74221,  $t_r \leq 7 \text{ ns}$ ,  $t_f \leq 7 \text{ ns}$ , for SN54/74LS221,  $t_r \leq 15 \text{ ns}$ ,  $t_f \leq 6 \text{ ns}$ .  
 E. All measurements are made between the 1.5-V points of the indicated transitions for the SN54/74221 or between the 1.3-V points for the SN54/74LS221.

Figure 2. Load Circuits and Voltage Waveforms

SN54221, SN54LS221, SN74221, SN74LS221  
 DUAL MONOSTABLE MULTIVIBRATORS  
 WITH SCHMITT-TRIGGER INPUTS

SDLS213B – DECEMBER 1983 – REVISED NOVEMBER 2004

TYPICAL CHARACTERISTICS (SN54/74221 ONLY)†

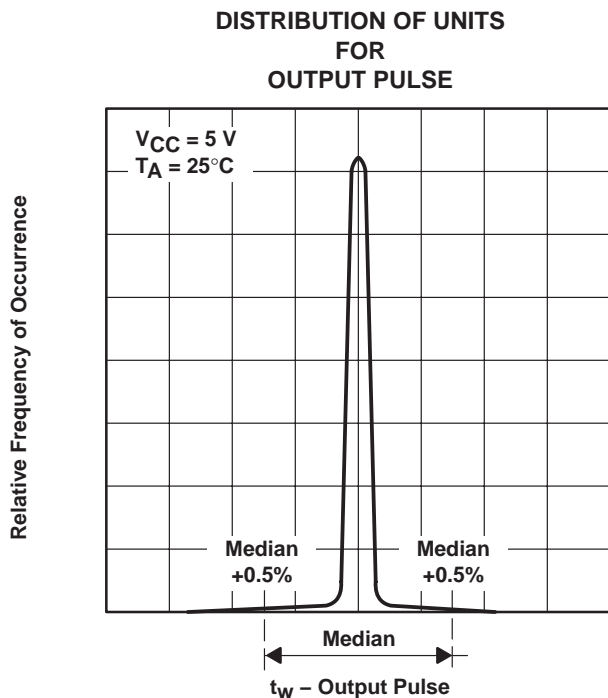

Figure 3

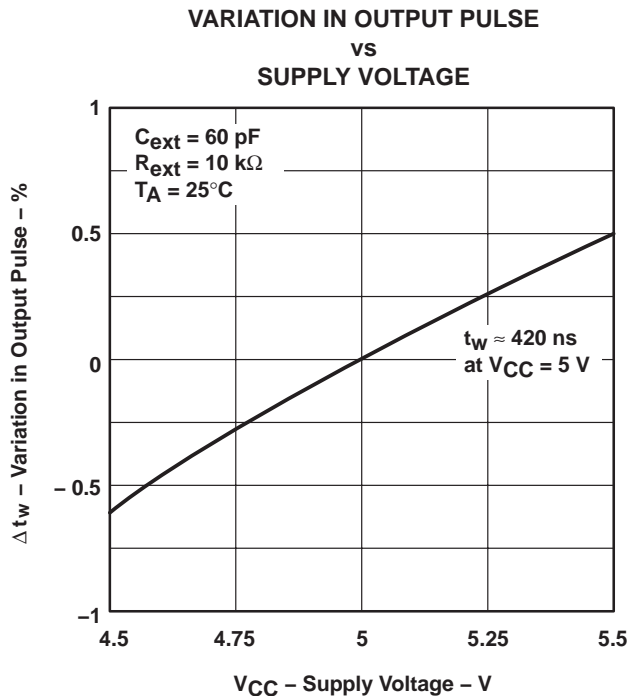

Figure 4

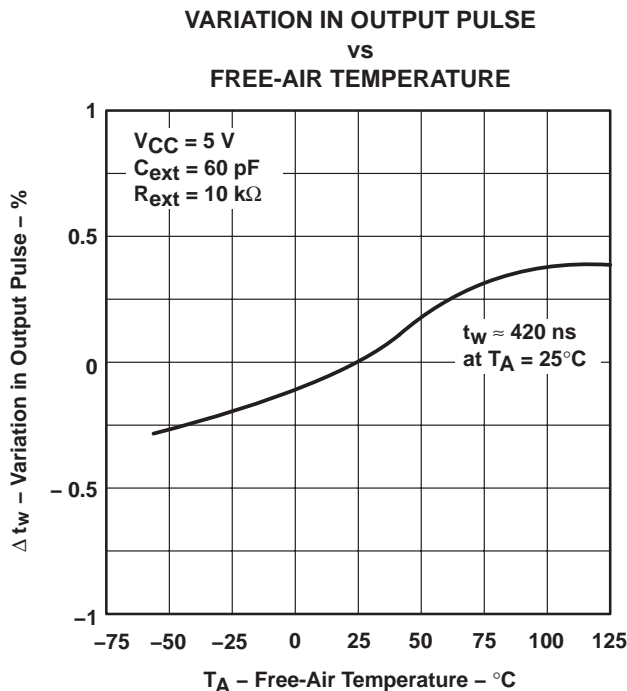

Figure 5

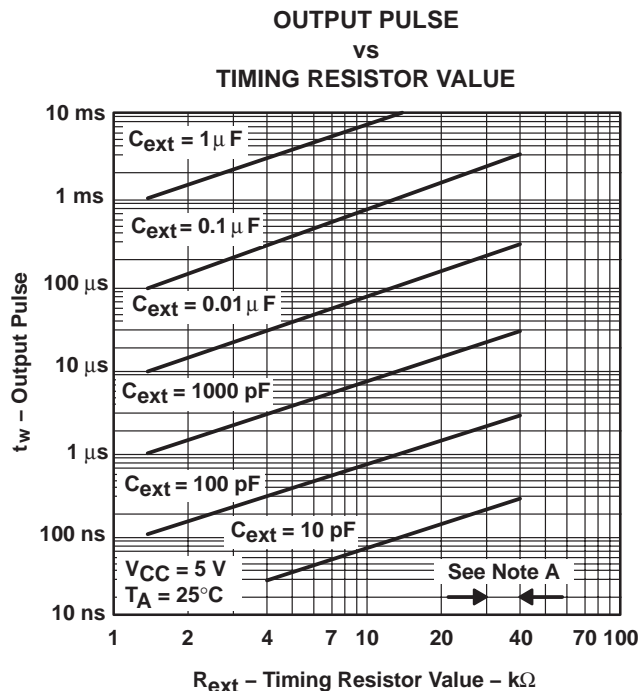

Figure 6

† Data for temperatures below 0°C and above 70°C, and for supply voltages below 4.75 V and above 5.25 V are applicable for the SN54221 only.  
 NOTE A: These values of resistance exceed the maximum recommended for use over the full military temperature range of the SN54221.

PACKAGING INFORMATION

Orderable Device	Status <sup>(1)</sup>	Package Type	Package Drawing	Pins	Package Qty	Eco Plan <sup>(2)</sup>	Lead/Ball Finish	MSL Peak Temp <sup>(3)</sup>
5962-8771101EA	ACTIVE	CDIP	J	16	1	TBD	Call TI	Level-NC-NC-NC
76042012A	ACTIVE	LCCC	FK	20	1	TBD	Call TI	Level-NC-NC-NC
7604201EA	ACTIVE	CDIP	J	16	1	TBD	Call TI	Level-NC-NC-NC
7604201FA	ACTIVE	CFP	W	16	1	TBD	Call TI	Level-NC-NC-NC
JM38510/31402B2A	ACTIVE	LCCC	FK	20	1	TBD	Call TI	Level-NC-NC-NC
JM38510/31402BEA	ACTIVE	CDIP	J	16	1	TBD	Call TI	Level-NC-NC-NC
JM38510/31402BFA	ACTIVE	CFP	W	16	1	TBD	Call TI	Level-NC-NC-NC
SN54221J	ACTIVE	CDIP	J	16	1	TBD	Call TI	Level-NC-NC-NC
SN54LS221J	ACTIVE	CDIP	J	16	1	TBD	Call TI	Level-NC-NC-NC
SN74221N	ACTIVE	PDIP	N	16	25	Pb-Free (RoHS)	CU NIPDAU	Level-NC-NC-NC
SN74221NE4	ACTIVE	PDIP	N	16	25	Pb-Free (RoHS)	CU NIPDAU	Level-NC-NC-NC
SN74LS221D	ACTIVE	SOIC	D	16	40	Green (RoHS & no Sb/Br)	CU NIPDAU	Level-1-260C-UNLIM
SN74LS221DBR	ACTIVE	SSOP	DB	16	2000	Green (RoHS & no Sb/Br)	CU NIPDAU	Level-1-260C-UNLIM
SN74LS221DBRE4	ACTIVE	SSOP	DB	16	2000	Green (RoHS & no Sb/Br)	CU NIPDAU	Level-1-260C-UNLIM
SN74LS221DE4	ACTIVE	SOIC	D	16	40	Green (RoHS & no Sb/Br)	CU NIPDAU	Level-1-260C-UNLIM
SN74LS221DR	ACTIVE	SOIC	D	16	2500	Green (RoHS & no Sb/Br)	CU NIPDAU	Level-1-260C-UNLIM
SN74LS221DRE4	ACTIVE	SOIC	D	16	2500	Green (RoHS & no Sb/Br)	CU NIPDAU	Level-1-260C-UNLIM
SN74LS221N	ACTIVE	PDIP	N	16	25	Pb-Free (RoHS)	CU NIPDAU	Level-NC-NC-NC
SN74LS221N3	OBSOLETE	PDIP	N	16		TBD	Call TI	Call TI
SN74LS221NE4	ACTIVE	PDIP	N	16	25	Pb-Free (RoHS)	CU NIPDAU	Level-NC-NC-NC
SN74LS221NSR	ACTIVE	SO	NS	16	2000	Green (RoHS & no Sb/Br)	CU NIPDAU	Level-1-260C-UNLIM
SN74LS221NSRE4	ACTIVE	SO	NS	16	2000	Green (RoHS & no Sb/Br)	CU NIPDAU	Level-1-260C-UNLIM
SNJ54221J	ACTIVE	CDIP	J	16	1	TBD	Call TI	Level-NC-NC-NC
SNJ54LS221FK	ACTIVE	LCCC	FK	20	1	TBD	Call TI	Level-NC-NC-NC
SNJ54LS221J	ACTIVE	CDIP	J	16	1	TBD	Call TI	Level-NC-NC-NC
SNJ54LS221W	ACTIVE	CFP	W	16	1	TBD	Call TI	Level-NC-NC-NC

<sup>(1)</sup> The marketing status values are defined as follows:

**ACTIVE:** Product device recommended for new designs.

**LIFEBUY:** TI has announced that the device will be discontinued, and a lifetime-buy period is in effect.

**NRND:** Not recommended for new designs. Device is in production to support existing customers, but TI does not recommend using this part in a new design.

**PREVIEW:** Device has been announced but is not in production. Samples may or may not be available.

**OBSOLETE:** TI has discontinued the production of the device.

<sup>(2)</sup> Eco Plan - The planned eco-friendly classification: Pb-Free (RoHS) or Green (RoHS & no Sb/Br) - please check

<http://www.ti.com/productcontent> for the latest availability information and additional product content details.

**TBD:** The Pb-Free/Green conversion plan has not been defined.

**Pb-Free (RoHS):** TI's terms "Lead-Free" or "Pb-Free" mean semiconductor products that are compatible with the current RoHS requirements for all 6 substances, including the requirement that lead not exceed 0.1% by weight in homogeneous materials. Where designed to be soldered at high temperatures, TI Pb-Free products are suitable for use in specified lead-free processes.

**Green (RoHS & no Sb/Br):** TI defines "Green" to mean Pb-Free (RoHS compatible), and free of Bromine (Br) and Antimony (Sb) based flame retardants (Br or Sb do not exceed 0.1% by weight in homogeneous material)

<sup>(3)</sup> MSL, Peak Temp. -- The Moisture Sensitivity Level rating according to the JEDEC industry standard classifications, and peak solder temperature.

**Important Information and Disclaimer:**The information provided on this page represents TI's knowledge and belief as of the date that it is provided. TI bases its knowledge and belief on information provided by third parties, and makes no representation or warranty as to the accuracy of such information. Efforts are underway to better integrate information from third parties. TI has taken and continues to take reasonable steps to provide representative and accurate information but may not have conducted destructive testing or chemical analysis on incoming materials and chemicals. TI and TI suppliers consider certain information to be proprietary, and thus CAS numbers and other limited information may not be available for release.

In no event shall TI's liability arising out of such information exceed the total purchase price of the TI part(s) at issue in this document sold by TI to Customer on an annual basis.

J (R-GDIP-T\*\*)

14 LEADS SHOWN

CERAMIC DUAL IN-LINE PACKAGE



DIM \ PINS **	14	16	18	20
A	0.300 (7,62) BSC	0.300 (7,62) BSC	0.300 (7,62) BSC	0.300 (7,62) BSC
B MAX	0.785 (19,94)	.840 (21,34)	0.960 (24,38)	1.060 (26,92)
B MIN	—	—	—	—
C MAX	0.300 (7,62)	0.300 (7,62)	0.310 (7,87)	0.300 (7,62)
C MIN	0.245 (6,22)	0.245 (6,22)	0.220 (5,59)	0.245 (6,22)



4040083/F 03/03

- NOTES:
- All linear dimensions are in inches (millimeters).
  - This drawing is subject to change without notice.
  - This package is hermetically sealed with a ceramic lid using glass frit.
  - Index point is provided on cap for terminal identification only on press ceramic glass frit seal only.
  - Falls within MIL STD 1835 GDIP1-T14, GDIP1-T16, GDIP1-T18 and GDIP1-T20.

W (R-GDFP-F16)

CERAMIC DUAL FLATPACK

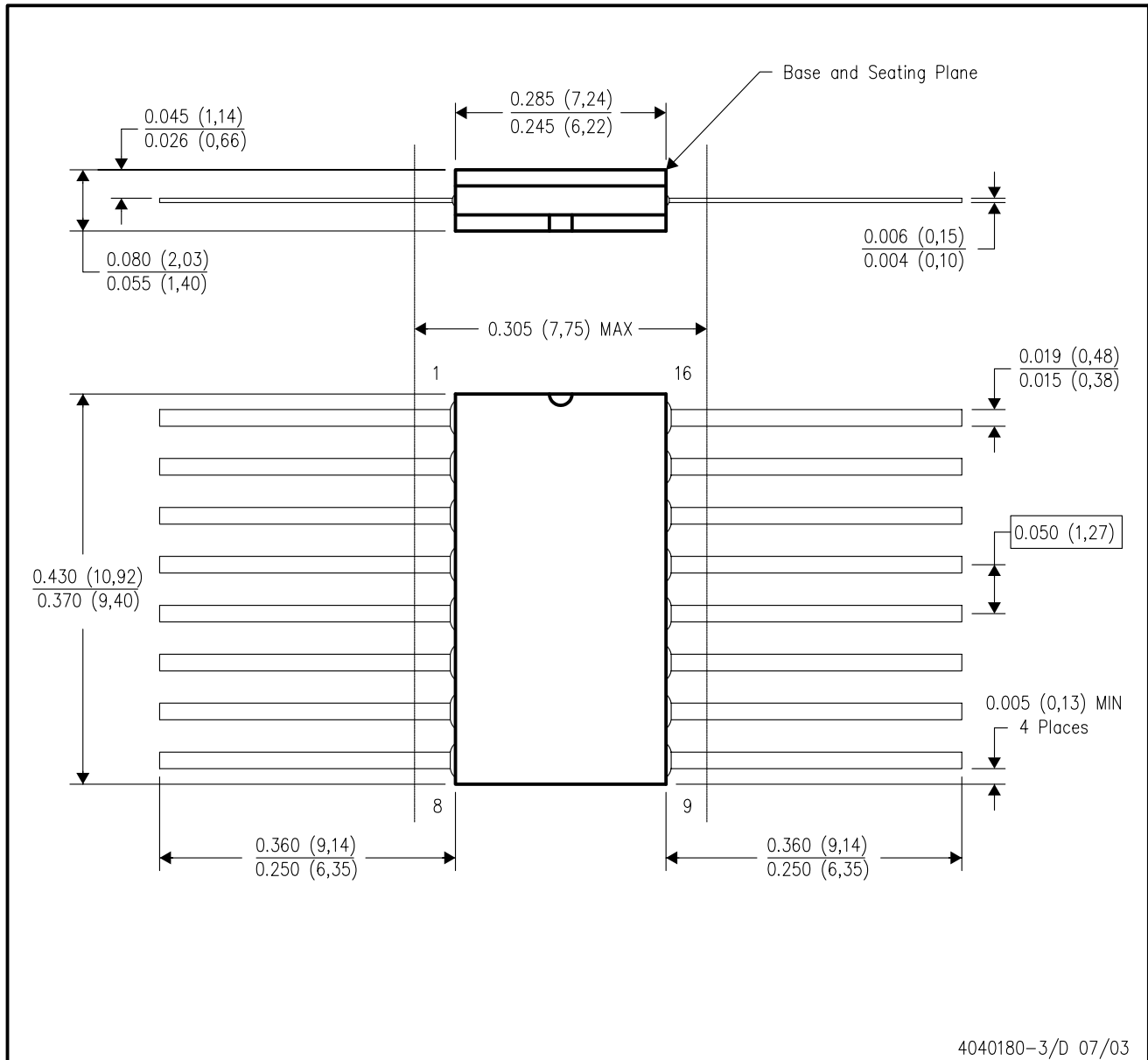

- NOTES:
- All linear dimensions are in inches (millimeters).
  - This drawing is subject to change without notice.
  - This package can be hermetically sealed with a ceramic lid using glass frit.
  - Index point is provided on cap for terminal identification only.
  - Falls within MIL STD 1835 GDFP1-F16 and JEDEC MO-092AC

FK (S-CQCC-N\*\*)

LEADLESS CERAMIC CHIP CARRIER

28 TERMINAL SHOWN

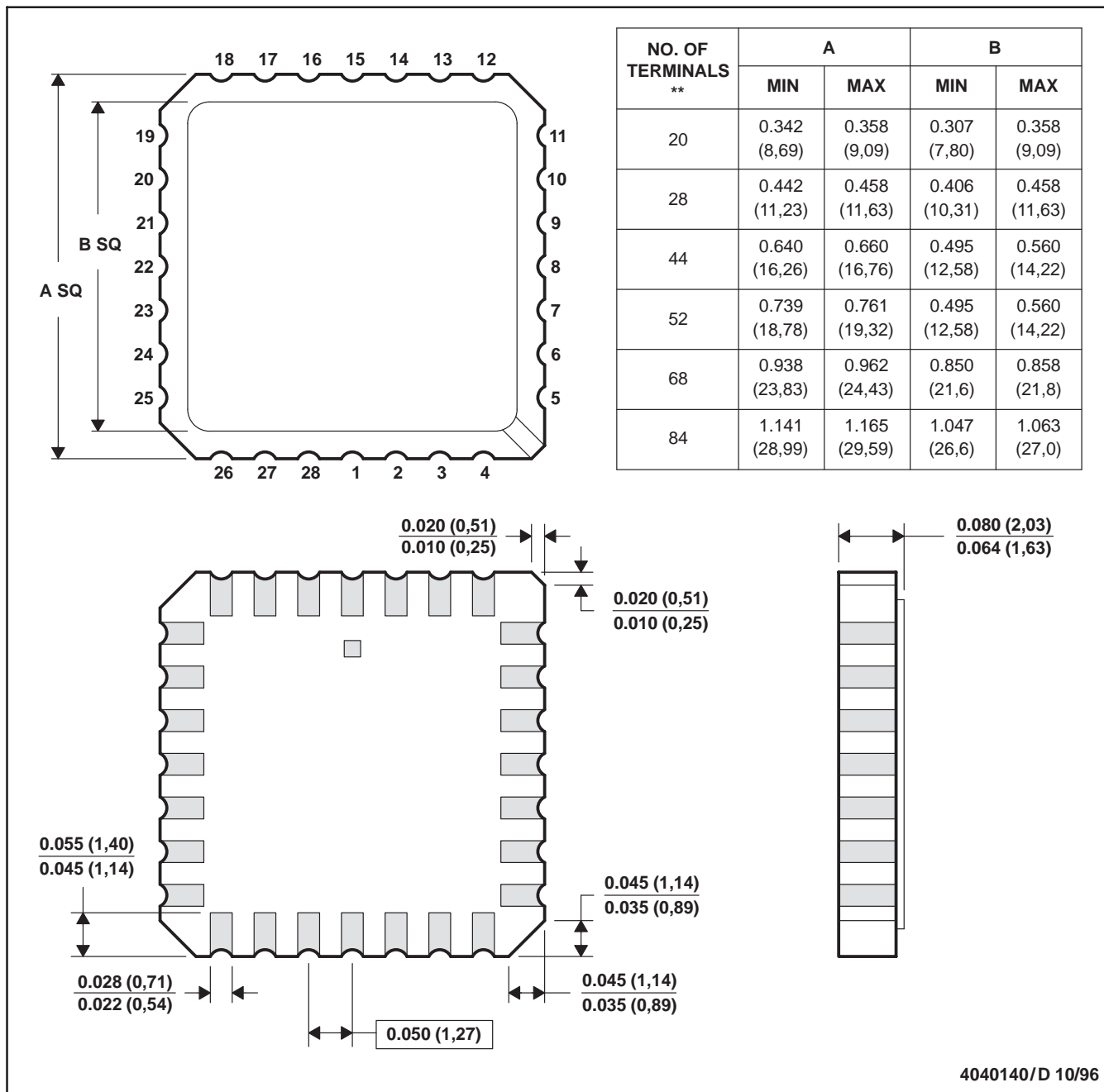

- NOTES:
- A. All linear dimensions are in inches (millimeters).
  - B. This drawing is subject to change without notice.
  - C. This package can be hermetically sealed with a metal lid.
  - D. The terminals are gold plated.
  - E. Falls within JEDEC MS-004

N (R-PDIP-T\*\*)

PLASTIC DUAL-IN-LINE PACKAGE

16 PINS SHOWN



- NOTES:
- A. All linear dimensions are in inches (millimeters).
  - B. This drawing is subject to change without notice.
  - Falls within JEDEC MS-001, except 18 and 20 pin minimum body length (Dim A).
  - The 20 pin end lead shoulder width is a vendor option, either half or full width.

D (R-PDSO-G16)

PLASTIC SMALL-OUTLINE PACKAGE

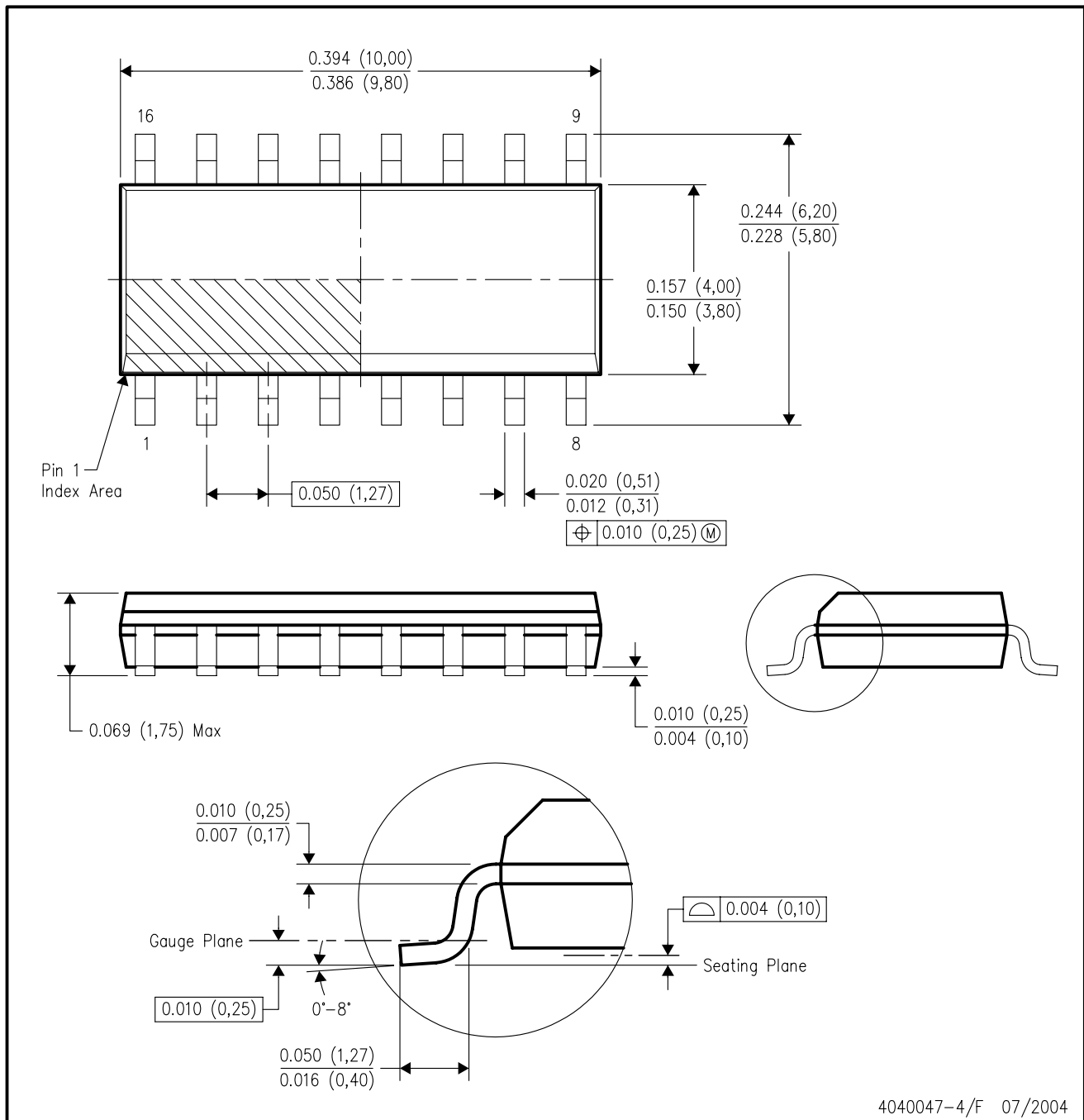

- NOTES:
- A. All linear dimensions are in inches (millimeters).
  - B. This drawing is subject to change without notice.
  - C. Body dimensions do not include mold flash or protrusion not to exceed 0.006 (0,15).
  - D. Falls within JEDEC MS-012 variation AC.

# MECHANICAL DATA

NS (R-PDSO-G\*\*)

PLASTIC SMALL-OUTLINE PACKAGE

14-PINS SHOWN



- NOTES:
- A. All linear dimensions are in millimeters.
  - B. This drawing is subject to change without notice.
  - C. Body dimensions do not include mold flash or protrusion, not to exceed 0,15.

DB (R-PDSO-G\*\*)

PLASTIC SMALL-OUTLINE

28 PINS SHOWN



- NOTES: A. All linear dimensions are in millimeters.  
 B. This drawing is subject to change without notice.  
 C. Body dimensions do not include mold flash or protrusion not to exceed 0,15.  
 D. Falls within JEDEC MO-150

## IMPORTANT NOTICE

Texas Instruments Incorporated and its subsidiaries (TI) reserve the right to make corrections, modifications, enhancements, improvements, and other changes to its products and services at any time and to discontinue any product or service without notice. Customers should obtain the latest relevant information before placing orders and should verify that such information is current and complete. All products are sold subject to TI's terms and conditions of sale supplied at the time of order acknowledgment.

TI warrants performance of its hardware products to the specifications applicable at the time of sale in accordance with TI's standard warranty. Testing and other quality control techniques are used to the extent TI deems necessary to support this warranty. Except where mandated by government requirements, testing of all parameters of each product is not necessarily performed.

TI assumes no liability for applications assistance or customer product design. Customers are responsible for their products and applications using TI components. To minimize the risks associated with customer products and applications, customers should provide adequate design and operating safeguards.

TI does not warrant or represent that any license, either express or implied, is granted under any TI patent right, copyright, mask work right, or other TI intellectual property right relating to any combination, machine, or process in which TI products or services are used. Information published by TI regarding third-party products or services does not constitute a license from TI to use such products or services or a warranty or endorsement thereof. Use of such information may require a license from a third party under the patents or other intellectual property of the third party, or a license from TI under the patents or other intellectual property of TI.

Reproduction of information in TI data books or data sheets is permissible only if reproduction is without alteration and is accompanied by all associated warranties, conditions, limitations, and notices. Reproduction of this information with alteration is an unfair and deceptive business practice. TI is not responsible or liable for such altered documentation.

Resale of TI products or services with statements different from or beyond the parameters stated by TI for that product or service voids all express and any implied warranties for the associated TI product or service and is an unfair and deceptive business practice. TI is not responsible or liable for any such statements.

Following are URLs where you can obtain information on other Texas Instruments products and application solutions:

<b>Products</b>		<b>Applications</b>	
Amplifiers	<a href="http://amplifier.ti.com">amplifier.ti.com</a>	Audio	<a href="http://www.ti.com/audio">www.ti.com/audio</a>
Data Converters	<a href="http://dataconverter.ti.com">dataconverter.ti.com</a>	Automotive	<a href="http://www.ti.com/automotive">www.ti.com/automotive</a>
DSP	<a href="http://dsp.ti.com">dsp.ti.com</a>	Broadband	<a href="http://www.ti.com/broadband">www.ti.com/broadband</a>
Interface	<a href="http://interface.ti.com">interface.ti.com</a>	Digital Control	<a href="http://www.ti.com/digitalcontrol">www.ti.com/digitalcontrol</a>
Logic	<a href="http://logic.ti.com">logic.ti.com</a>	Military	<a href="http://www.ti.com/military">www.ti.com/military</a>
Power Mgmt	<a href="http://power.ti.com">power.ti.com</a>	Optical Networking	<a href="http://www.ti.com/opticalnetwork">www.ti.com/opticalnetwork</a>
Microcontrollers	<a href="http://microcontroller.ti.com">microcontroller.ti.com</a>	Security	<a href="http://www.ti.com/security">www.ti.com/security</a>
		Telephony	<a href="http://www.ti.com/telephony">www.ti.com/telephony</a>
		Video & Imaging	<a href="http://www.ti.com/video">www.ti.com/video</a>
		Wireless	<a href="http://www.ti.com/wireless">www.ti.com/wireless</a>

Mailing Address: Texas Instruments  
Post Office Box 655303 Dallas, Texas 75265