

DS7838/DS8838 Quad Unified Bus Transceiver

General Description

The DS7838/DS8838 are quad high speed drivers/receivers designed for use in bus organized data transmission systems interconnected by terminated 120Ω impedance lines. The external termination is intended to be 180Ω resistor from the bus to the +5V logic supply together with a 390Ω resistor from the bus to ground. The bus can be terminated at one or both ends. Low bus pin current allows up to 27 driver/receiver pairs to utilize a common bus. The bus loading is unchanged when $V_{CC} = 0V$. The receivers incorporate hysteresis to greatly enhance bus noise immunity. One two-input NOR gate is included to disable all drivers in a package simultaneously. Receiver performance is optimized for systems with bus rise and fall times $\leq 1.0 \mu s/V$.

Features

- 4 totally separate driver/receiver pairs per package
- 1V typical receiver input hysteresis
- Receiver hysteresis independent of receiver output load
- Guaranteed minimum bus noise immunity of 1.3V, 2V typ.
- Temperature-insensitive receiver thresholds track bus logic levels
- 20 μA typical bus terminal current with normal V_{CC} or with $V_{CC} = 0V$
- Open collector driver output allows wire-OR connection
- High speed
- Series 74 TTL compatible driver and disable inputs and receiver outputs

Typical Application

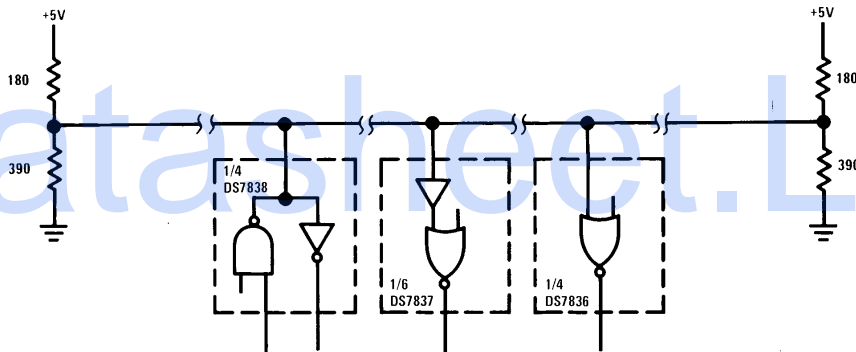

Connection Diagram

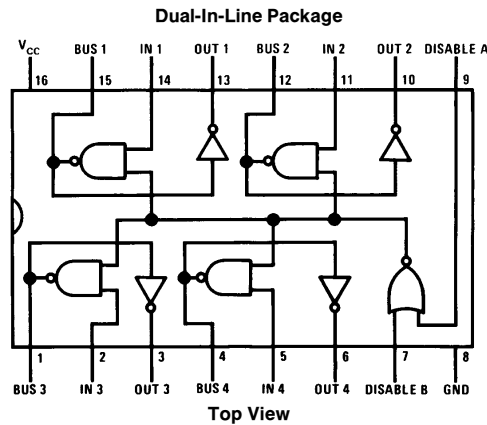

Order Number DS7838J, DS8838M or DS8838N
See NS Package Number J16A, M16A or N16A

TL/F/5812-2

Datasheet.Live

Absolute Maximum Ratings (Note 1)

If Military/Aerospace specified devices are required, please contact the National Semiconductor Sales Office/Distributors for availability and specifications.

Supply Voltage	7V
Input and Output Voltage	5.5V
Storage Temperature Range	-65°C to +150°C
Lead Temperature, (Soldering, 4 sec.)	260°C

*Derate cavity package 9.6 mW/°C above 25°C; derate molded DIP package 10.9 mW/°C above 25°C; derate SO package 8.01 mW/°C above 25°C.

Maximum Power Dissipation* at 25°C

Cavity Package	1433 mW
Molded DIP Package	1362 mW
SO Package	1002 mW

Operating Conditions

Operating Temperature Range	-55°C to +125°C
DS7838	0°C to +70°C
DS8838	
Supply Voltage (V _{CC})	4.5V ≤ V _{CC} ≤ 5.5V
DS7838	4.75V ≤ V _{CC} ≤ 5.25V
DS8838	

Electrical Characteristics

DS7838/DS8838: The following apply for V_{MIN} ≤ V_{CC} ≤ V_{MAX}, T_{MIN} ≤ T_A ≤ T_{MAX}, unless otherwise specified (Notes 2 and 3)

Symbol	Parameter	Conditions	Min	Typ	Max	Units	
DRIVER AND DISABLE INPUTS							
V _{IH}	Logical "1" Input Voltage		2.0			V	
V _{IL}	Logical "0" Input Voltage				0.8	V	
I _I	Logical "1" Input Current	V _{IN} = 5.5V			1	mA	
I _{IH}	Logical "1" Input Current	V _{IN} = 2.4V			40	μA	
I _{IL}	Logical "0" Input Current	V _{IN} = 0.4V			-1.6	mA	
V _{CL}	Input Diode Clamp Voltage	I _{DIS} = -12 mA, I _{IN} = -12 mA, I _{BUS} = -12 mA, T _A = 25°C		-1	-1.5	V	
DRIVER OUTPUT/RECEIVER INPUT							
V _{OLB}	Low Level Bus Voltage	V _{DIS} = 0.8V, V _{IN} = 2V, I _{BUS} = 50 mA		0.4	0.7	V	
I _{IHB}	Maximum Bus Current	V _{IN} = 0.8V, V _{BUS} = 4V, V _{CC} = V _{MAX}		20	100	μA	
I _{ILB}	Maximum Bus Current	V _{IN} = 0.8V, V _{BUS} = 4V, V _{CC} = 0V		2	100	μA	
V _{IH}	High Level Receiver Threshold	V _{IND} = 0.8V, I _{OL} = 16 mA V _{CC} = Max	DS7838	1.65	2.25	2.65	V
			DS8838	1.80	2.25	2.50	V
V _{IL}	Low Level Receiver Threshold	V _{IND} = 0.8V, V _{OH} = -400 μA V _{CC} = Min	DS7838	0.97	1.30	1.63	V
			DS8838	1.05	1.30	1.55	V
RECEIVER OUTPUT							
V _{OH}	Logical "1" Output Voltage	V _{IN} = 0.8V, V _{BUS} = 0.5V, I _{OH} = -400 μA	2.4			V	
V _{OL}	Logical "0" Output Voltage	V _{IN} = 0.8V, V _{BUS} = 4V, I _{OL} = 16 mA		0.25	0.4	V	
I _{OS}	Output Short Circuit Current	V _{DIS} = 0.8V, V _{IN} = 0.8V, V _{BUS} = 0.5V, V _{OS} = 0V, V _{CC} = V _{MAX} , (Note 4)	-18		-55	mA	
I _{CC}	Supply Current	V _{DIS} = 0V, V _{IN} = 2V, (Per Package)		50	70	mA	

Electrical Characteristics

DS7838/DS8838: The following apply for $V_{MIN} \leq V_{CC} \leq V_{MAX}$, $T_{MIN} \leq T_A \leq T_{MAX}$, unless otherwise specified (Notes 2 and 3)
(Continued)

Symbol	Parameter	Conditions	Min	Typ	Max	Units
RECEIVER OUTPUT (Continued)						
t_{pd}	Propagation Delays (Note 8) Disable to Bus "1"	(Note 5)		19	30	ns
	Disable to Bus "0"	(Note 5)		15	23	ns
	Driver Input to Bus "1"	(Note 5)		17	25	ns
	Driver Input to Bus "0"	(Note 5)		9	15	ns
	Bus to Logical "1" Receiver Output	(Note 6)		20	30	ns
	Bus to Logical "0" Receiver Output	(Note 7)		18	30	ns

Note 1: "Absolute Maximum Ratings" are those values beyond which the safety of the device cannot be guaranteed. Except for "Operating Temperature Range" they are not meant to imply that the devices should be operated at these limits. The table of "Electrical Characteristics" provides conditions for actual device operation.

Note 2: Unless otherwise specified min/max limits apply across the -55°C to $+125^{\circ}\text{C}$ temperature range for the DS7838 and across the 0°C to $+70^{\circ}\text{C}$ range for the DS8838. All typical values are for $T_A = 25^{\circ}\text{C}$ and $V_{CC} = 5\text{V}$.

Note 3: All currents into device pins shown as positive, out of device pins as negative, all voltages referenced to ground unless otherwise noted. All values shown as max or min on absolute value basis.

Note 4: Only one output at a time should be shorted.

Note 5: 91Ω from bus pin to V_{CC} and 200Ω from bus pin to ground, $C_{LOAD} = 15\text{ pF}$ total. Measured from $V_{IN} = 1.5\text{V}$ to $V_{BUS} = 1.5\text{V}$, $V_{IN} = 0\text{V}$ to 3.0V pulse.

Note 6: Fan-out of 10 load, $C_{LOAD} = 15\text{ pF}$ total. Measured from $V_{IN} = 1.3\text{V}$ to $V_{OUT} = 1.5\text{V}$, $V_{IN} = 0\text{V}$ to 3.0V pulse.

Note 7: Fan-out of 10 load, $C_{LOAD} = 15\text{ pF}$ total. Measured from $V_{IN} = 2.3\text{V}$ to $V_{OUT} = 1.5\text{V}$, $V_{IN} = 0\text{V}$ to 3.0V pulse.

Note 8: These apply for $V_{CC} = 5\text{V}$, $T_A = 25^{\circ}\text{C}$ unless otherwise specified.

Physical Dimensions inches (millimeters)

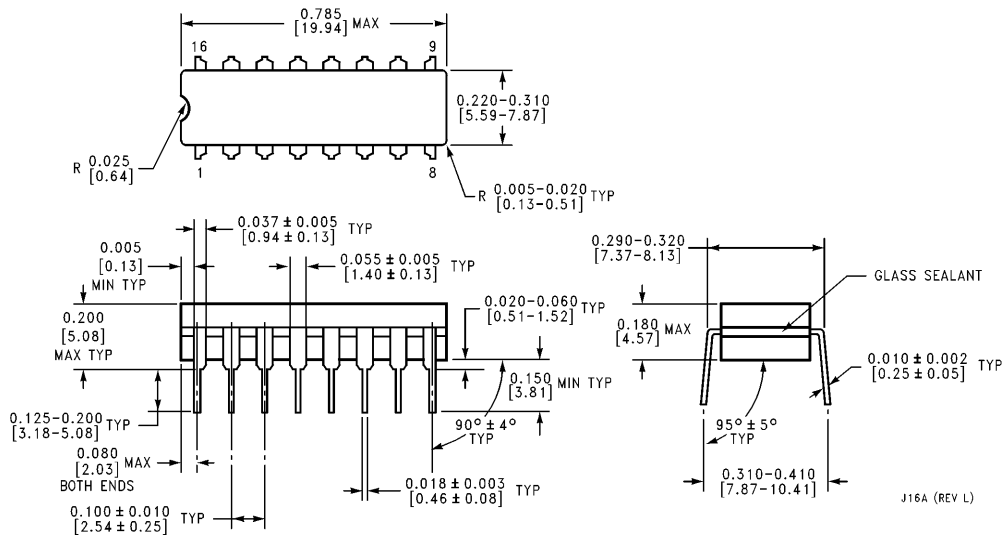

Ceramic Dual-In-Line Package (J)
Order Number DS7838J
NS Package Number J16A

