

## DM64ALS273/DM74ALS273 Octal D-Type Edge-Triggered Flip-Flop with Clear

### General Description

These monolithic, positive-edge-triggered flip-flops utilize TTL circuitry to implement D-type flip-flop logic with a direct clear input.

Information at the D inputs meeting the setup requirements is transferred to the Q outputs on the positive-going edge of the clock pulse. Clock triggering occurs at a particular voltage level and is not directly related to the transition time of the positive-going pulse. When the clock input is at either the high or low level, the D input signal has no effect at the output.

The DM64ALS273 version features the same performance as the standard version DM74ALS273 with a guarantee over an extended temperature range (–40°C to +85°C)

### Features

- Switching specifications at 50 pF
- Switching specifications guaranteed over full temperature and  $V_{CC}$  range
- Buffer-type outputs and improved AC offer significant advantage over 'LS273.
- Advanced oxide-isolated, ion-implanted Schottky TTL process
- Functionally and pin-for-pin compatible with 'LS273.
- DM64ALS273 guarantee over extended temperature –40°C to +85°C

### Connection Diagram

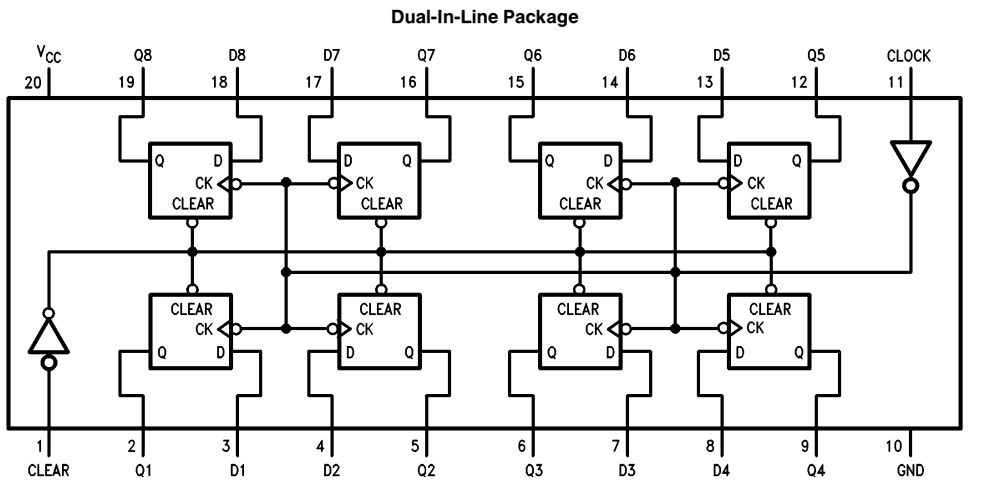

Order Number DM64ALS273N, DM64ALS273WM, DM74ALS273WM,  
DM74ALS273N, DM74ALS273SJ or DM74ALS273MSA  
See NS Package Number M20B, M20D, MSA20 or N20A

DM64ALS273/DM74ALS273 Octal D-Type Edge-Triggered Flip-Flop with Clear

## Absolute Maximum Ratings

Supply Voltage	7V
Input Voltage	7V
Operating Free Air Temperature Range	
DM64ALS	−40°C to +85°C
DM74ALS	0°C to +70°C
Storage Temperature Range	−65°C to +150°C
Typical $\theta_{JA}$	
N Package	60.0°C/W
M Package	79.0°C/W

Note: The “Absolute Maximum Ratings” are those values beyond which the safety of the device cannot be guaranteed. The device should not be operated at these limits. The parametric values defined in the “Electrical Characteristics” table are not guaranteed at the absolute maximum ratings. The “Recommended Operating Conditions” table will define the conditions for actual device operation.

Note: This product meets application requirements of 500 temperature cycles from −65°C to +150°C.

## Recommended Operating Conditions

Symbol	Parameter	DM64ALS273			DM74ALS273			Units
		Min	Nom	Max	Min	Nom	Max	
V <sub>CC</sub>	Supply Voltage	4.5	5	5.5	4.5	5	5.5	V
V <sub>IH</sub>	High Level Input Voltage	2			2			V
V <sub>IL</sub>	Low Level Input Voltage			0.8			0.8	V
I <sub>OH</sub>	High Level Output Current			−2.6			−2.6	mA
I <sub>OL</sub>	Low Level Output Current			24			24	mA
f <sub>CLK</sub>	Clock Frequency	0		35	0		35	MHz
t <sub>w(CLK)</sub>	Width of Clock Pulse	High	14		14			ns
		Low	14		14			ns
t <sub>w</sub>	Width of Clear Pulse	Low	10		10			ns
t <sub>SU</sub>	Data Setup Time		10 ↑		10 ↑			ns
		Clear Inactive	15 ↑		15 ↑			
t <sub>H</sub>	Data Hold Time		0 ↑		0 ↑			ns
T <sub>A</sub>	Free Air Operating Temperature		−40		85		70	°C

The (↑) arrow indicates the positive edge of the Clock is used for reference.

## Electrical Characteristics

over recommended operating free air temperature range. All typical values are measured at V<sub>CC</sub> = 5V, T<sub>A</sub> = 25°C.

Symbol	Parameter	Conditions	Min	Typ	Max	Units	
V <sub>IK</sub>	Input Clamp Voltage	V <sub>CC</sub> = 4.5V, I <sub>I</sub> = −18 mA			−1.5	V	
V <sub>OH</sub>	High Level Output Voltage	V <sub>CC</sub> = 4.5V	I <sub>OH</sub> = −2.6 mA	2.4	3.3		V
		V <sub>CC</sub> = 4.5V to 5.5V	I <sub>OH</sub> = −400 μA	V <sub>CC</sub> − 2			V
V <sub>OL</sub>	Low Level Output Voltage	V <sub>CC</sub> = 4.5V	I <sub>OL</sub> = 12 mA		0.25	0.4	V
			I <sub>OL</sub> = 24 mA		0.35	0.5	V
I <sub>I</sub>	Input Current @ Max. Input Voltage	V <sub>CC</sub> = 5.5V, V <sub>IH</sub> = 7V			0.1	mA	
I <sub>IH</sub>	High Level Input Current	V <sub>CC</sub> = 5.5V, V <sub>IH</sub> = 2.7V			20	μA	
I <sub>IL</sub>	Low Level Input Current	V <sub>CC</sub> = 5.5V, V <sub>IL</sub> = 0.4V			−0.2	mA	
I <sub>O</sub>	Output Drive Current	V <sub>CC</sub> = 5.5V	V <sub>O</sub> = 2.25V	−30		−112	mA
I <sub>CC</sub>	Supply Current	V <sub>CC</sub> = 5.5V	Outputs High		11	20	mA
			Outputs Low		19	29	mA

## Switching Characteristics

over recommended operating free air temperature range (Note 1).

Symbol	Parameter	Conditions	From	To	DM64ALS273		DM74ALS273		Units
					Min	Max	Min	Max	
f <sub>MAX</sub>	Maximum Clock Frequency	V <sub>CC</sub> = 4.5V to 5.5V R <sub>L</sub> = 500Ω C <sub>L</sub> = 50 pF			35		35		MHz
t <sub>PHL</sub>	Propagation Delay Time High to Low Level Output		Clear	Any Q	4	18	4	18	ns
t <sub>PLH</sub>	Propagation Delay Time Low to High Level Output		Clock	Any Q	2	12	2	12	ns
t <sub>PHL</sub>	Propagation Delay Time High to Low Level Output		Clock	Any Q	3	15	3	15	ns

**Note 1:** See Section 5 for test waveforms and output load.

## Function Table (Each Flip-Flop)

Inputs			Output Q
Clear	Clock	D	
L	X	X	L
H	↑	H	H
H	↑	L	L
H	L	X	Q <sub>0</sub>

L = Low State, H = High State, X = Don't Care

↑ = Positive Edge Transition, Q<sub>0</sub> = Previous Condition of Q

# Logic Diagram

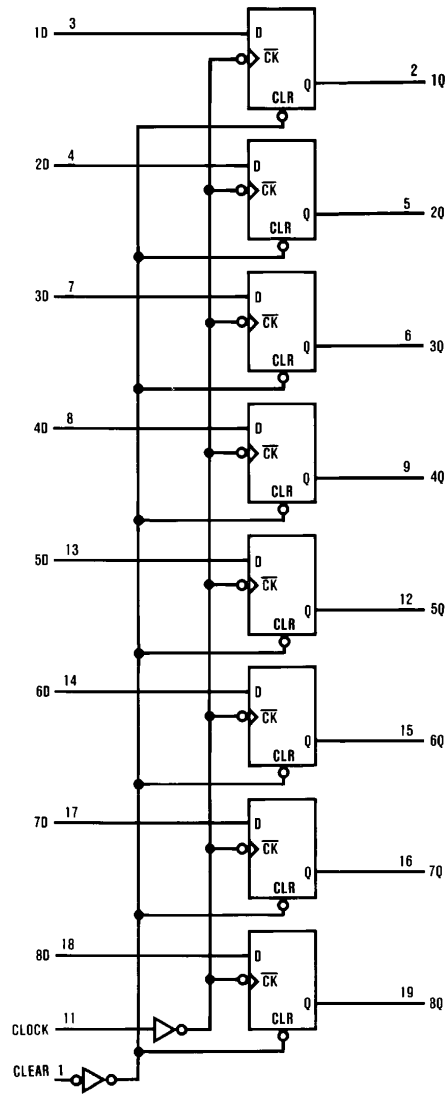

TL/F/6216-2

**Physical Dimensions** inches (millimeters)

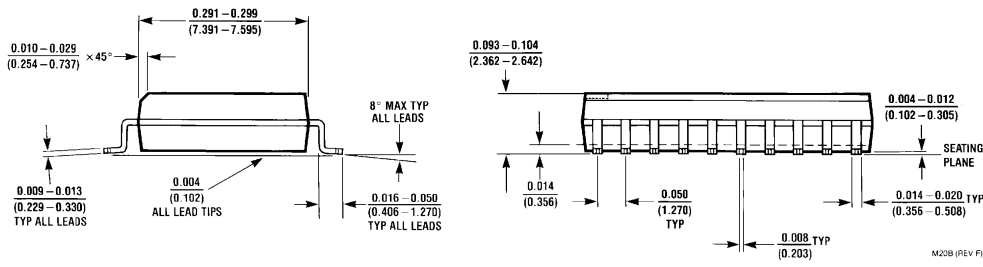
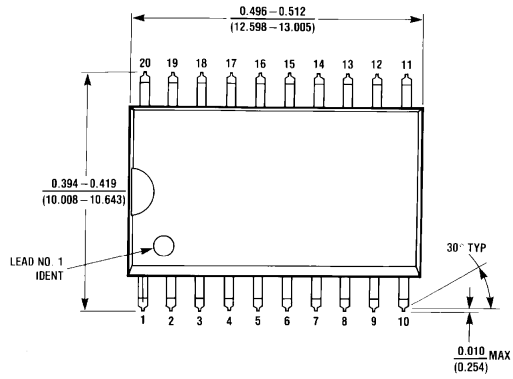

**S.O. Package (M)**  
**Order Number DM74ALS273WM, DM64ALS273WM**  
**NS Package Number M20B**

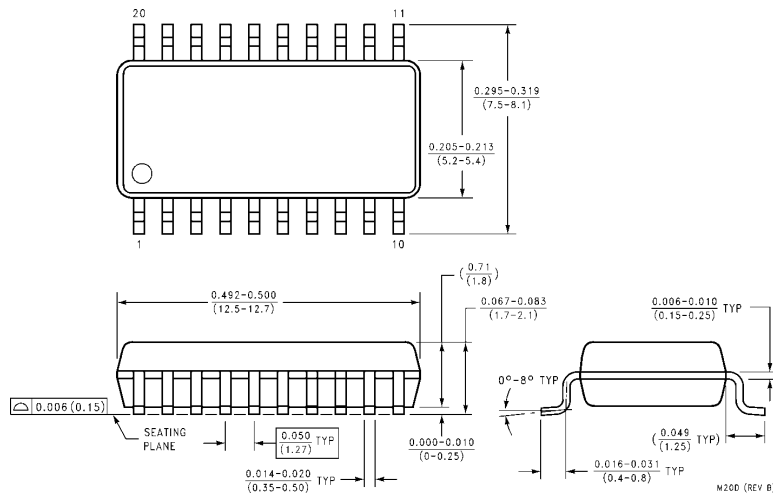

**Small Outline Package (SJ)**  
**Order Number DM74ALS273SJ**  
**NS Package Number M20D**

**Physical Dimensions** inches (millimeters) (Continued)

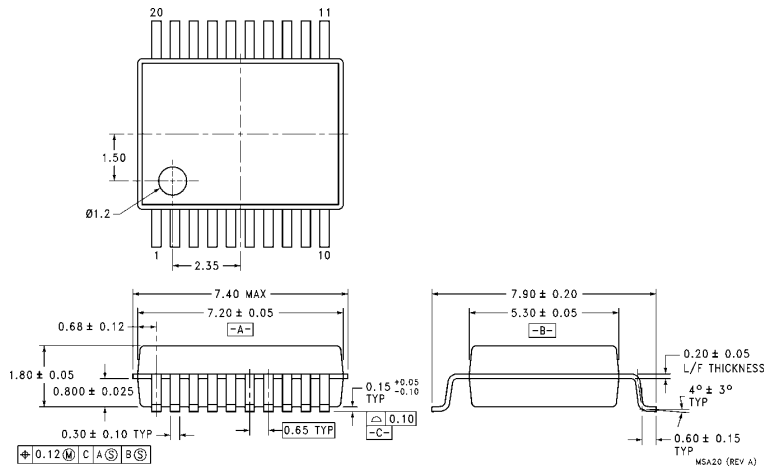

**Molded Shrink Small Outline Package (MSA)**  
**Order Number DM74ALS273MSA**  
**NS Package Number MSA20**

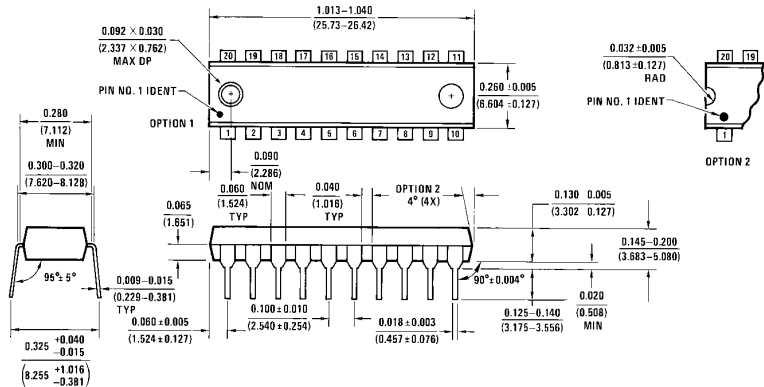

**Molded Dual-In-Line Package (N)**  
**Order Number DM74ALS273N, DM64ALS273N**  
**NS Package Number N20A**

**LIFE SUPPORT POLICY**

NATIONAL'S PRODUCTS ARE NOT AUTHORIZED FOR USE AS CRITICAL COMPONENTS IN LIFE SUPPORT DEVICES OR SYSTEMS WITHOUT THE EXPRESS WRITTEN APPROVAL OF THE PRESIDENT OF NATIONAL SEMICONDUCTOR CORPORATION. As used herein:

1. Life support devices or systems are devices or systems which, (a) are intended for surgical implant into the body, or (b) support or sustain life, and whose failure to perform, when properly used in accordance with instructions for use provided in the labeling, can be reasonably expected to result in a significant injury to the user.
2. A critical component is any component of a life support device or system whose failure to perform can be reasonably expected to cause the failure of the life support device or system, or to affect its safety or effectiveness.

 <p><b>National Semiconductor Corporation</b>          1111 West Bardin Road          Arlington, TX 76017          Tel: 1(800) 272-9959          Fax: 1(800) 737-7018  <a href="http://www.national.com">http://www.national.com</a></p>	<p><b>National Semiconductor Europe</b>          Fax: +49 (0) 180-530 85 86          Email: <a href="mailto:europe.support@nsc.com">europe.support@nsc.com</a>          Deutsch Tel: +49 (0) 180-530 85 85          English Tel: +49 (0) 180-532 78 32          Français Tel: +49 (0) 180-532 93 58          Italiano Tel: +49 (0) 180-534 16 80</p>	<p><b>National Semiconductor Hong Kong Ltd.</b>          19th Floor, Straight Block,          Ocean Centre, 5 Canton Rd.          Tsimshatsui, Kowloon          Hong Kong          Tel: (852) 2737-1600          Fax: (852) 2736-9960</p>	<p><b>National Semiconductor Japan Ltd.</b>          Tel: 81-043-299-2308          Fax: 81-043-299-2408</p>
---	--	---	---

National does not assume any responsibility for use of any circuitry described, no circuit patent licenses are implied and National reserves the right at any time without notice to change said circuitry and specifications.

This datasheet has been download from:

[www.datasheetcatalog.com](http://www.datasheetcatalog.com)

Datasheets for electronics components.

# National Semiconductor was acquired by Texas Instruments.

[http://www.ti.com/corp/docs/investor\\_relations/pr\\_09\\_23\\_2011\\_national\\_semiconductor.html](http://www.ti.com/corp/docs/investor_relations/pr_09_23_2011_national_semiconductor.html)

This file is the datasheet for the following electronic components:

DM64ALS273 - <http://www.ti.com/product/dm64als273?HQS=TI-null-null-dscatalog-df-pf-null-ww>

DM74ALS273 - <http://www.ti.com/product/dm74als273?HQS=TI-null-null-dscatalog-df-pf-null-ww>