

REVISIONS			DCP NO. SPC-F005 * Effective: 7/8/02 * DCP No: 1398					
DCP #	REV	DESCRIPTION	DRAWN	DATE	CHECKD	DATE	APPRV	DATE
XX	XX	XXXX	XXXX	07-08-08	XXXX	07-08-08	XXXX	07-08-08
XXXX	XXXX		XXXX	07-08-08	XXXX	07-08-08	XXXX	07-08-08

MATERIAL

- 2-1. Frame : Thermoplastic PBT of UL 94V-0
- 2-2. Impeller : Thermoplastic PBT of UL 94V-0
- 2-3. Bobbin : Thermoplastic PBT of UL 94V-0
- 2-4. Lead Wire : UL1007, 24awg, +RED, -BLACK

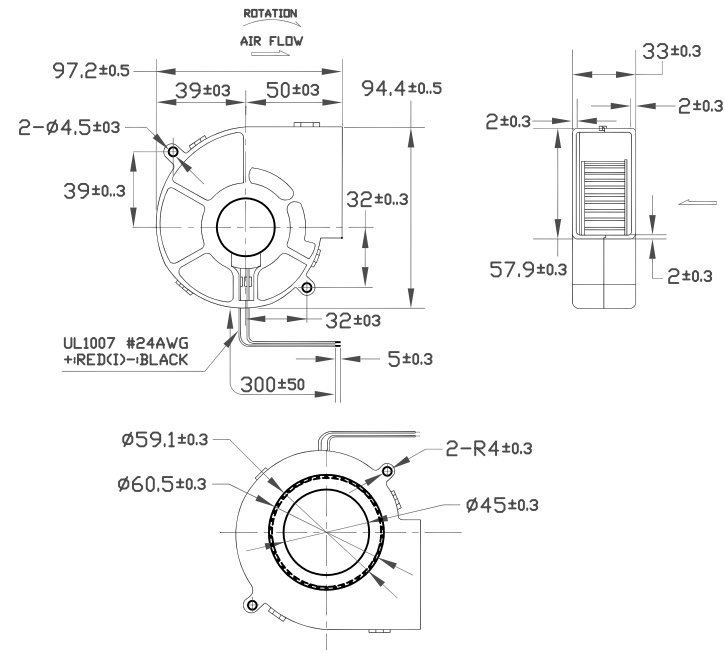

DISCLAIMER:
ALL STATEMENTS AND TECHNICAL INFORMATION CONTAINED HEREIN ARE BASED UPON INFORMATION AND/OR TESTS WE BELIEVE TO BE ACCURATE AND RELIABLE. SINCE CONDITIONS OF USE ARE BEYOND OUR CONTROL, THE USER SHALL DETERMINE THE SUITABILITY OF THE PRODUCT FOR THE INTENDED USE AND ASSUME ALL RISK AND LIABILITY WHATSOEVER IN CONNECTION THEREWITH.

TOLERANCES:
UNLESS OTHERWISE SPECIFIED, DIMENSIONS ARE FOR REFERENCE PURPOSES ONLY.

DRAWN BY:	DATE:
XXXX	07-08-08
CHECKED BY:	DATE:
XXXX	07-08-08
APPROVED BY:	DATE:
XXXX	07-08-08

DRAWING TITLE:			
DC BRUSHLESS BLOWER			
SIZE	DWG. NO.	ELECTRONIC FILE	REV
A	MC19649	70K8532.dwg	
SCALE:	U.O.M.:	SHEET:	
NTS	INCHES [mm]	1 OF 1	



ALL RIGHTS RESERVED. NO PORTION OF THIS PUBLICATION, WHETHER IN WHOLE OR IN PART CAN BE REPRODUCED WITHOUT THE EXPRESS WRITTEN CONSENT OF SPC TECHNOLOGY.
SPC-F005.DWG

REVISIONS

DOC. NO. SPC-F005 * Effective: 7/8/02 * DCP No: 1398

DCP #	REV	DESCRIPTION	DRAWN	DATE	CHECKD	DATE	APPRVD	DATE
XX	XX	XXXX	XXXX	07-08-08	XXXX	07-08-08	XXXX	07-08-08
XXXX	XXXX		XXXX	07-08-08	XXXX	07-08-08	XXXX	07-08-08

SPECIFICATIONS

- 1-1. Rated Voltage : 12 VDC.
- 1-2. Operating Voltage Range : 6~12 VDC
- 1-3. Starting Voltage : 6 VDC (25deg.C POWER ON/OFF)
- 1-4 Rated Speed : 3600 RPM ± 10%
- 1-5. Air Delivery : 30.5 CFM
- 1-6. Static Pressure : 0.92 Inch-H₂O
- 1-7. Rated Current : 0.72 AMP
- 1-8. Rated Power : 8.6 WATTS
- 1-9. Noise Level : 55.8 dB(A)
- 1-10. Direction of Rotation : Counter-clockwise viewed from front of fan blade
- 1-11. Operating Temperature : -10 to +70 deg. C
- 1-12. Storage Temperature : -40 to +70 deg. C
- 1-13. Bearing System : Precision ball bearing system
- 1-14. Weight : 185 g
- 1-15. Safety : UL/CUR/TUV/CE Approvals
- 1-16. Vibration : Vibration of acceleration 1.5G and frequency 5~50~5Hz is applied in all 3 directions(X,Y,Z), in cycles of 1 minute each, for a total vibration time of 30 minutes.
- 1-17. Locked Rotor Protection : Automatic Restart Capability
Note: In a situation where the fan is locked by an external force while the electricity is on, an increase in coil temperature will be prevented by temporarily turning off the electrical power to the motor. The fan will automatically restart when the locked rotor condition is released.



DISCLAIMER:
ALL STATEMENTS AND TECHNICAL INFORMATION CONTAINED HEREIN ARE BASED UPON INFORMATION AND/OR TESTS WE BELIEVE TO BE ACCURATE AND RELIABLE. SINCE CONDITIONS OF USE ARE BEYOND OUR CONTROL, THE USER SHALL DETERMINE THE SUITABILITY OF THE PRODUCT FOR THE INTENDED USE AND ASSUME ALL RISK AND LIABILITY WHATSOEVER IN CONNECTION THEREWITH.

TOLERANCES:
UNLESS OTHERWISE SPECIFIED, DIMENSIONS ARE FOR REFERENCE PURPOSES ONLY.

DRAWN BY:	DATE:
XXXX	07-08-08
CHECKED BY:	DATE:
XXXX	07-08-08
APPROVED BY:	DATE:
XXXX	07-08-08

DRAWING TITLE:			
DC BRUSHLESS BLOWER			
SIZE	DWG. NO.	ELECTRONIC FILE	REV
A	MC19649		
SCALE: NTS	U.O.M.: INCHES [mm]	SHEET: 1	OF 1



ALL RIGHTS RESERVED. NO PORTION OF THIS PUBLICATION, WHETHER IN WHOLE OR IN PART CAN BE REPRODUCED WITHOUT THE EXPRESS WRITTEN CONSENT OF SPC TECHNOLOGY.
SPC-F005.DWG

REVISIONS			DOC. NO. SPC-F005 * Effective: 7/8/02 * DCP No: 1398					
DCP #	REV	DESCRIPTION	DRAWN	DATE	CHECKD	DATE	APPRVD	DATE
XX	XX	XXXX	XXXX	07-08-08	XXXX	07-08-08	XXXX	07-08-08
XXXX	XXXX		XXXX	07-08-08	XXXX	07-08-08	XXXX	07-08-08

PERFORMANCE CURVES

STATIC PRESSURE

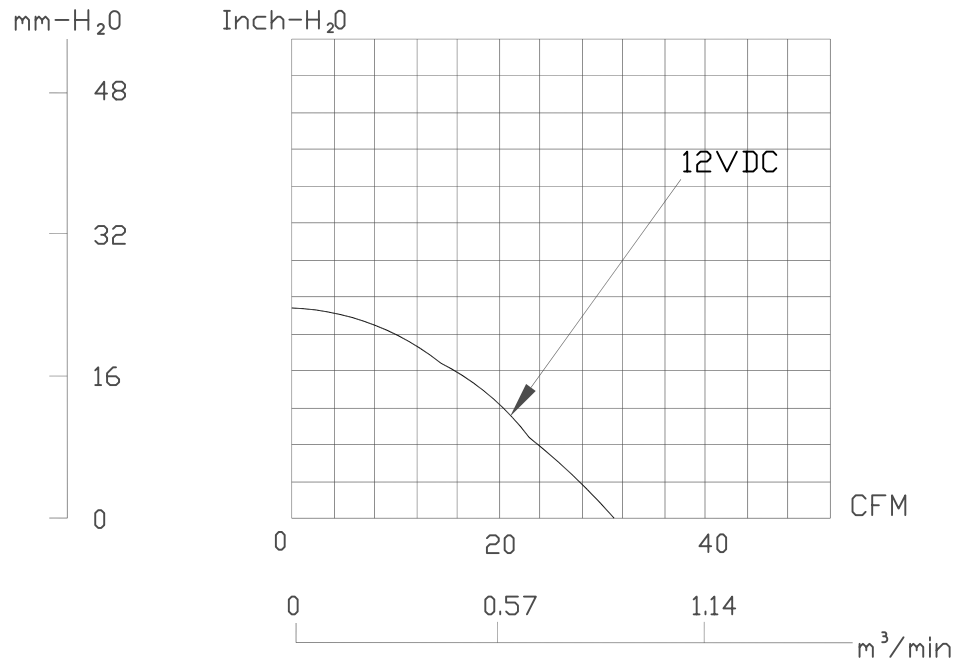

DISCLAIMER:
ALL STATEMENTS AND TECHNICAL INFORMATION CONTAINED HEREIN ARE BASED UPON INFORMATION AND/OR TESTS WE BELIEVE TO BE ACCURATE AND RELIABLE. SINCE CONDITIONS OF USE ARE BEYOND OUR CONTROL, THE USER SHALL DETERMINE THE SUITABILITY OF THE PRODUCT FOR THE INTENDED USE AND ASSUME ALL RISK AND LIABILITY WHATSOEVER IN CONNECTION THEREWITH.

TOLERANCES:
UNLESS OTHERWISE SPECIFIED, DIMENSIONS ARE FOR REFERENCE PURPOSES ONLY.

DRAWN BY:	DATE:
XXXX	07-08-08
CHECKED BY:	DATE:
XXXX	07-08-08
APPROVED BY:	DATE:
XXXX	07-08-08

DRAWING TITLE:				DC BRUSHLESS BLOWER			
SIZE	DWG. NO.	ELECTRONIC FILE		REV			
A	MC19649						
SCALE: NTS		U.O.M.: INCHES [mm]		SHEET: 1 OF 1			



ALL RIGHTS RESERVED. NO PORTION OF THIS PUBLICATION, WHETHER IN WHOLE OR IN PART CAN BE REPRODUCED WITHOUT THE EXPRESS WRITTEN CONSENT OF SPC TECHNOLOGY.
SPC-F005.DWG

REVISIONS			DOC. NO. SPC-F005 * Effective: 7/8/02 * DCP No: 1398					
DCP #	REV	DESCRIPTION	DRAWN	DATE	CHECKD	DATE	APPRVD	DATE
XX	XX	XXXX	XXXX	07-08-08	XXXX	07-08-08	XXXX	07-08-08
XXXX	XXXX		XXXX	07-08-08	XXXX	07-08-08	XXXX	07-08-08

CHARACTERISTICS

- 1. Motor Design : DC brushless 4 pole motor design.
- 2. Insulation Resistance : More than 10M ohm between internal stator and lead wire(+) measured at DC 500V.
- 3. Dielectric Strength : Applied AC 500V for one minute or AC 600V for 2 seconds between housing and lead wire(+).
- 4. Noise Level : Measured in a semi-anechoic chamber with background noise level below 15 dB(A).The fan is running in free air with the microphone at a distance of one meter from the fan intake.
- 5. Input Power, Current & Speed : Measured after continuous 10 minute operation at rated voltage in clean air, and at ambient temperature of 25 degrees C.
- 6. Tolerance : ±15% on rated power and current.
- 7. Air Performance : Measured by a double chamber. The values are recorded when the fan speed has stabilized at rated voltage.



DISCLAIMER:
ALL STATEMENTS AND TECHNICAL INFORMATION CONTAINED HEREIN ARE BASED UPON INFORMATION AND/OR TESTS WE BELIEVE TO BE ACCURATE AND RELIABLE. SINCE CONDITIONS OF USE ARE BEYOND OUR CONTROL, THE USER SHALL DETERMINE THE SUITABILITY OF THE PRODUCT FOR THE INTENDED USE AND ASSUME ALL RISK AND LIABILITY WHATSOEVER IN CONNECTION THEREWITH.

**TOLERANCES:
UNLESS OTHERWISE SPECIFIED, DIMENSIONS ARE FOR REFERENCE PURPOSES ONLY.**

DRAWN BY:	DATE:
XXXX	07-08-08
CHECKED BY:	DATE:
XXXX	07-08-08
APPROVED BY:	DATE:
XXXX	07-08-08

DRAWING TITLE:				DC BRUSHLESS BLOWER			
SIZE	DWG. NO.	ELECTRONIC FILE		REV			
A	MC19649						
SCALE: NTS		U.O.M.: INCHES [mm]		SHEET: 1 OF 1			