

**Multimode 850 nm 1.0625 GBd
Fibre Channel 1.3 Gigabit Ethernet
1x9 Transceiver**

V23826-K305-Cxx/Cxxx

Features

- Compliant with Fibre Channel and Gigabit Ethernet standard
- Meets mezzanine standard height of 9.8 mm
- Compact integrated transceiver unit with
 - VCSEL transmitter
 - Integrated receiver
 - Duplex SC receptacle
- Class 1 FDA and IEC laser safety compliant
- Single power supply (5 V or 3.3 V)
- Signal detect indicator (PECL and TTL version)
- PECL differential inputs and outputs
- Process plug included
- Performance exceeds FC 100-M5-SLI
- Wave solderable and washable with process plug inserted
- For distances of up to 550 m on multimode fiber

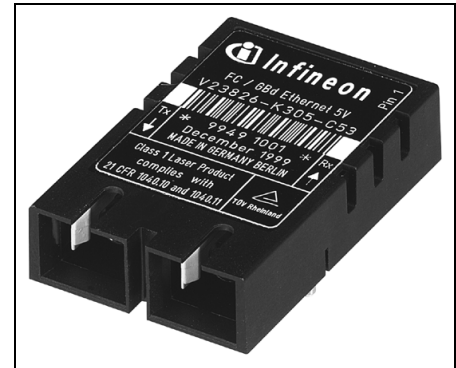

| Part Number | Voltage | Signal Detect | Input | Output |
|--------------------------------|------------------------------------|---------------|-------|--------|
| V23826-K305-C13 | 5 V | PECL | AC | DC |
| V23826-K305-C313 | 3.3 V | | | |
| V23826-K305-C53 | 5 V | TTL | AC | AC |
| V23826-K305-C353 | 3.3 V | | | |
| V23826-K305-C63 ¹⁾ | 5 V | PECL | DC | DC |
| V23826-K305-C363 ¹⁾ | 3.3 V | | | |
| V23826-K305-C73 | 5 V | PECL | AC | AC |
| V23826-K305-C373 | 3.3 V | | | |
| Add Suffix to PIN | Shield Options | | | |
| -C3 | Metallized cover, forward springs | | | |
| -D3 | Metallized cover, backward springs | | | |

¹⁾ Standard version

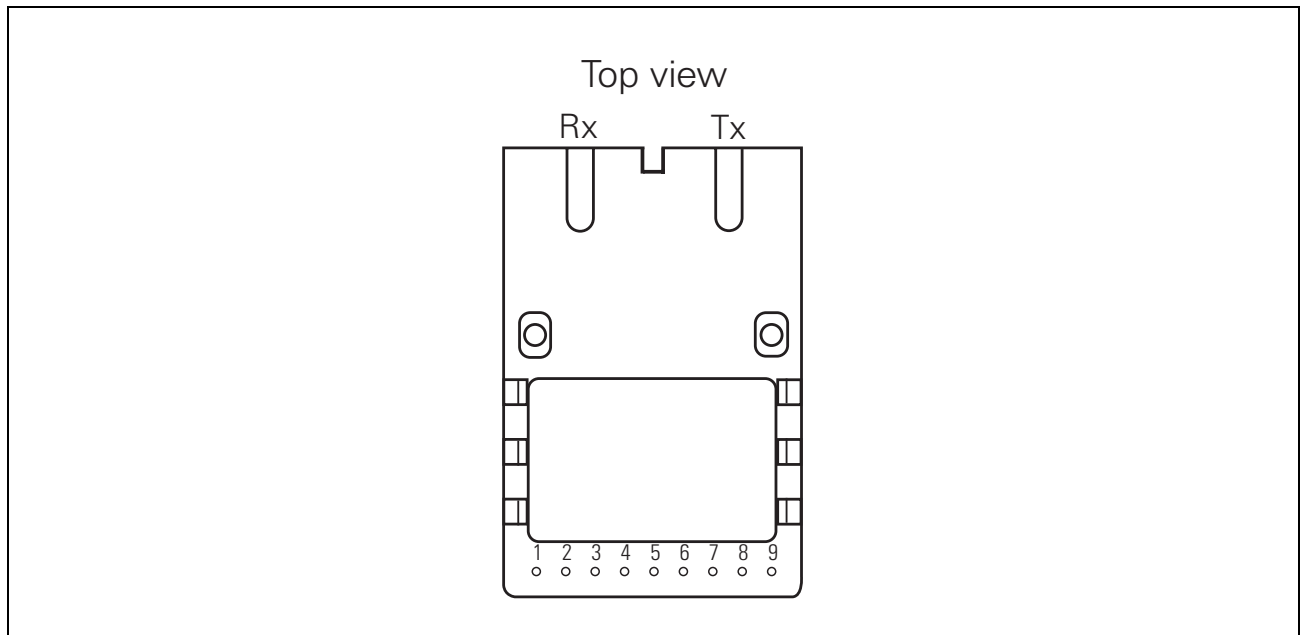
Pin Configuration

Figure 1
Pin Description

| Pin No. | Symbol | Level/ Logic | Function | Description |
|---------|-------------------|--|------------------|--|
| 1 | RxV _{EE} | Power Supply | Rx Ground | Negative power supply, normally ground |
| 2 | RD | PECL Output | Rx Output Data | Receiver output data |
| 3 | RDn | | | Inverted receiver output data |
| 4 | RxSD | PECL Output active high (TTL C53/C353) | Rx Signal Detect | High level on this output shows there is an optical signal |
| 5 | RxV _{CC} | Power Supply | Rx 3.3 V/5 V | Positive power supply, 3.3 V/5 V |
| 6 | TxV _{CC} | | Tx 3.3 V/5 V | |
| 7 | TxDn | PECL Input | Tx Input Data | Inverted transmitter input data |
| 8 | TxD | | | Transmitter input data |
| 9 | TxV _{EE} | Power Supply | Tx Ground | Negative power supply, normally ground |
| S1/S2 | Case | Mech. Support | Support | Not connected |

Description

Description

The Infineon multi mode transceiver is based on the Physical Medium Depend (PMD) sublayer and baseband medium, type 1000BASE-SX (Long Wavelength Laser) (IEEE 802.3z) and complies with the Fibre Channel Physical and Signaling Interface (FC-PH), ANSI XSI TT Fibre Channel Physical Standard Class 100-M5-SLI, latest Revision.

The appropriate fiber optic cable is 62.5 μm or 50 μm multimode fiber with Duplex SC connector.

The Infineon multi mode transceiver is a single unit comprised of a transmitter, a receiver, and an SC receptacle. This design frees the customer from many alignment and PC board layout concerns.

The module is designed for low cost LAN, WAN, Gigabit Ethernet, and Fibre Channel applications. It can be used as the network end device interface in mainframes, workstations, servers, and storage devices, and in a broad range of network devices such as bridges, routers, intelligent hubs, and local and wide area switches.

This transceiver operates at 1.0625 Gbit/s and 1.3 Gbit/s from a single power supply (+5 V or 3.3 V). The full differential data inputs and outputs are PECL compatible.

Operating Range each Optical Fiber Type at 1.0625 GBd

| Fiber Type | Limit Values | | Unit |
|-----------------|--------------|------|--------|
| | min. | typ. | |
| 62.5 micron MFF | 2 to 260 | 400 | meters |
| 50.0 micron MFF | 2 to 550 | 700 | |

Functional Description

This transceiver is designed to transmit serial data via multimode cable.

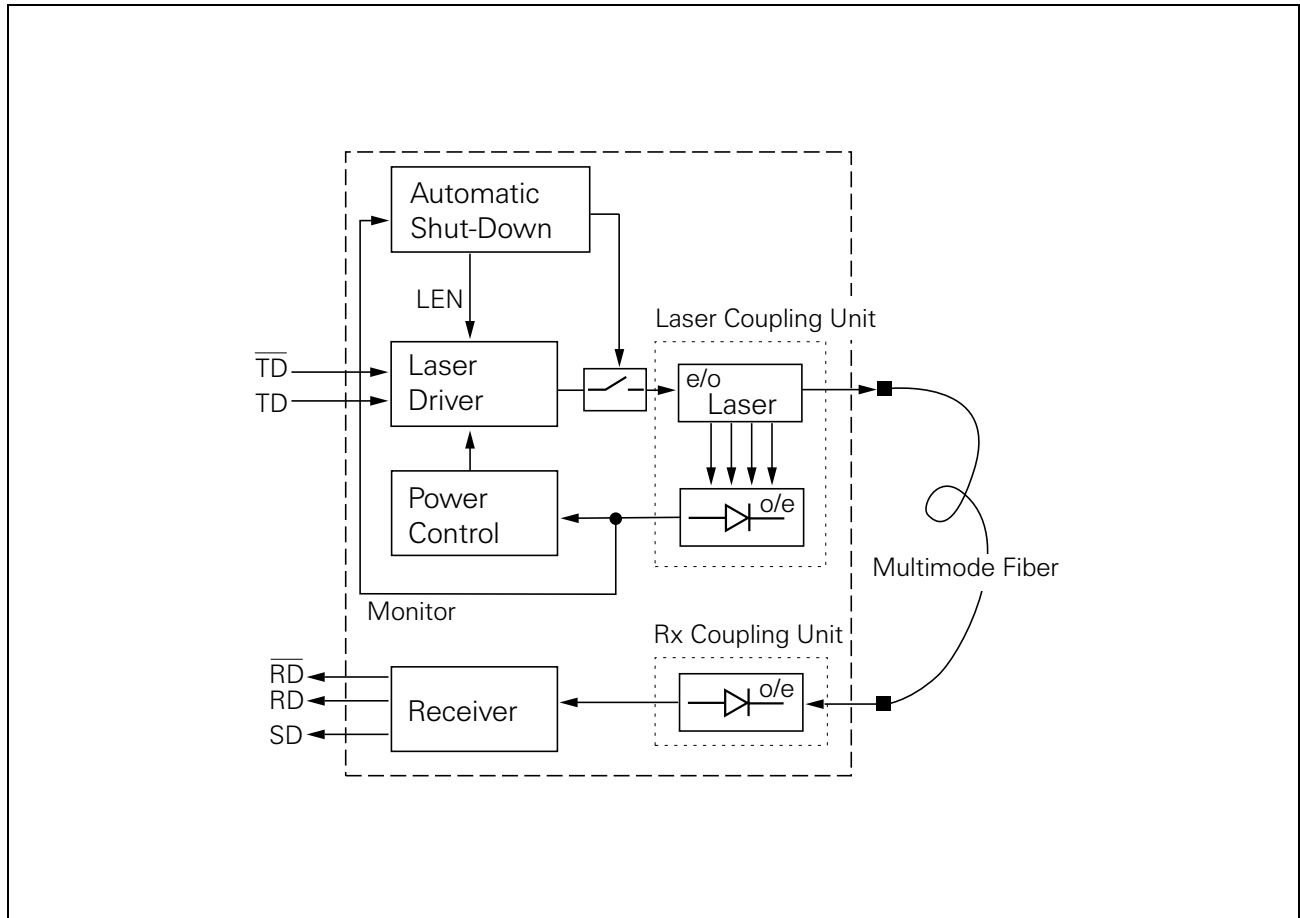

Figure 2 Functional Diagram

The receiver component converts the optical serial data into PECL compatible electrical data (RD and RDnot). The Signal Detect (SD, active high) shows whether an optical signal is present.

The transmitter converts electrical PECL compatible serial data (TD and TDnot) into optical serial data.

The following versions are available:

- 1 AC/DC Transceiver: Tx is AC coupled. Differential 100 Ω load. Rx has standard PECL output and is DC coupled.
- 2 AC/AC TTL Transceiver: Tx and Rx are AC coupled. Tx has differential 100 Ω load. Signal Detect is TTL compatible.
- 3 DC/DC Transceiver: Standard PECL inputs and outputs Tx and Rx are DC coupled.
- 4 AC/AC PECL Transceiver: Tx and Rx are AC coupled. Tx has differential 100 Ω load. Signal Detect is PECL compatible.

Description

The transmitter contains a laser driver circuit that drives the modulation and bias current of the laser diode. The currents are controlled by a power control circuit to guarantee constant output power of the laser over temperature and aging.

The power control uses the output of the monitor PIN diode (mechanically built into the laser coupling unit) as a controlling signal, to prevent the laser power from exceeding the operating limits.

Single fault condition is ensured by means of an integrated automatic shutdown circuit that disables the laser when it detects transmitter failures. A reset is only possible by turning the power off, and then on again.

The transceiver contains a supervisory circuit to control the power supply. This circuit generates an internal reset signal whenever the supply voltage drops below the reset threshold. It keeps the reset signal active for at least 140 milliseconds after the voltage has risen above the reset threshold. During this time the laser is inactive.

Regulatory Compliance

| Feature | Standard | Comments |
|--|---|---|
| Electrostatic Discharge (ESD) to the Electrical Pins | MIL-STD 883C Method 3015.4 | Class 1 (> 1000 V) |
| Immunity: Electrostatic Discharge (ESD) to the Duplex SC Receptacle | EN 61000-4-2 IEC 61000-4-2 | Discharges of ± 15 kV with an air discharge probe on the receptacle cause no damage. |
| Immunity: Radio Frequency Electromagnetic Field | EN 61000-4-3 IEC 61000-4-3 | With a field strength of 3 V/m rms, noise frequency ranges from 10 MHz to 1 GHz. No effect on transceiver performance between the specification limits. |
| Emission: Electromagnetic Interference EMI | FCC Class B EN 55022 Class B CISPR 22 | Noise frequency range: 30 MHz to 6 GHz; Margins depend on PCB layout and chassis design |

Technical Data
Absolute Maximum Ratings

| Parameter | Symbol | Limit Values | | Unit |
|---|--------------|-----------------|--------------|------|
| | | min. | max. | |
| Package Power Dissipation | | | 1.5 | W |
| Supply Voltage | 3.3 V 5 V | $V_{CC}-V_{EE}$ | 5 7 | V |
| Data Input Levels (PECL) | | | $V_{CC}+0.5$ | |
| Differential Data Input Voltage | | | 2.5 | |
| Operating Ambient Temperature | | 0 | 70 | °C |
| Storage Ambient Temperature | | -40 | 85 | |
| Soldering Conditions Temp/Time (MIL-STD 883C, Method 2003) | | | 250/5.5 | °C/s |

Exceeding any one of these values may destroy the device immediately.

Recommended Operating Conditions

| Parameter | Symbol | Limit Values | | | Unit |
|------------------------------|--------------|-----------------|-------------|-------------------------|------|
| | | min. | typ. | max. | |
| Ambient Temperature | T_{AMB} | 0 | | 70 | °C |
| Power Supply Voltage | 3.3 V 5 V | $V_{CC}-V_{EE}$ | 3.1 4.75 | 3.3 5 3.5 5.25 | V |
| Supply Current ¹⁾ | 3.3 V 5 V | I_{CC} | | 230 270 | mA |

Transmitter

| | | | | | |
|--|-----------------|-------|--|-------|----|
| Data Input High Voltage DC/DC | $V_{IH}-V_{CC}$ | -1165 | | -880 | mV |
| Data Input Low Voltage DC/DC | $V_{IL}-V_{CC}$ | -1810 | | -1475 | |
| Data Input Differential Voltage ²⁾ AC/DC, AC/AC TTL, AC/AC PECL | V_{DIFF} | 250 | | 1600 | |

Receiver

| | | | | | |
|-------------------------|-------------|-----|--|-----|----|
| Input Center Wavelength | λ_C | 770 | | 860 | nm |
|-------------------------|-------------|-----|--|-----|----|

¹⁾ For $V_{CC}-V_{EE}$ (min., max.) 50% duty cycle. The supply current does not include the load drive current of the receiver output. Add. max. 45 mA for the three outputs. Load is 50 Ω to $V_{CC}-2$ V.

²⁾ Version C63: Low > 1.2 V; high < $V_{CC}-0.8$ V
Version C363: Low > 1.2 V; high < V_{CC}

The electro-optical characteristics described in the following tables are only valid for use under the recommended operating conditions.

Transmitter Electro-Optical Characteristics

| Parameter | Symbol | Limit Values | | | Unit |
|--|----------------------------|--------------|--------------|--------------|-------|
| | | min. | typ. | max. | |
| Launched Power (Average) ¹⁾ | P_O | -9.5 | | -4 | dBm |
| Center Wavelength | λ_C | 830 | 850 | 860 | nm |
| Spectral Width (RMS) | σ_I | | | 0.85 | |
| Relative Intensity Noise | RIN | | | -117 | dB/Hz |
| Extinction Ratio (Dynamic) | ER | 9 | | | dB |
| Reset Threshold ²⁾ | 5 V 3.3 V V_{TH} | | 3.5 2.7 | | V |
| Rise/Fall Time, 20% - 80% | t_R, t_F | | | 0.26 | ns |
| Coupled Power Ratio | CPR | 9 | | | dB |
| Power Dissipation | 5 V 3.3 V P_{Dist} | | 0.40 0.23 | 0.62 0.39 | W |

¹⁾ Into multimode fiber, 62.5 μm or 50 μm diameter.

²⁾ Laser power is shut down if power supply is below V_{TH} and switched on if power supply is above V_{TH} .

Receiver Electro-Optical Characteristics

| Parameter | Symbol | Limit Values | | | Unit |
|--|---------------------------------------|--------------|------|-------|---------------|
| | | min. | typ. | max. | |
| Sensitivity (Average Power) ¹⁾ | P_{IN} | | -20 | -17 | dBm |
| Saturation (Average Power) | P_{SAT} | | | 0 | |
| Signal Detect Assert Level ²⁾ | P_{SDA} | | -24 | -18 | |
| Signal Detect Deassert Level ³⁾ | P_{SDD} | -30 | -27 | | |
| Signal Detect Hysteresis | P_{SDA} $-P_{SDD}$ | | 3 | | dB |
| Signal Detect Assert Time | t_{ASS} | | | 100 | μs |
| Signal Detect Deassert Time | t_{DAS} | | | 350 | |
| Output Low Voltage ⁴⁾ | $V_{OL}-V_{CC}$ | -1950 | | -1620 | mV |
| Output High Voltage ⁴⁾ | $V_{OH}-V_{CC}$ | -1100 | | -720 | |
| Signal Detect Output Voltage AC/AC TTL ⁵⁾ | Low High V_{SDL} V_{SDH} | 2.0 | | 0.5 | V |

Receiver Electro-Optical Characteristics (cont'd)

| Parameter | Symbol | Limit Values | | | Unit |
|--|------------|--------------|------|------|------|
| | | min. | typ. | max. | |
| Data Output Differential Voltage ⁶⁾ | V_{DIFF} | 0.5 | 0.8 | 1.23 | V |
| Output Data Rise/Fall Time, 20% - 80% | t_R, t_F | | | 375 | ps |
| Return Loss of Receiver | A_{RL} | 12 | | | dB |
| Power Dissipation | P_{Disr} | | | | W |
| | 5 V | | 0.63 | 0.68 | |
| | 3.3 V | | 0.30 | 0.42 | |

¹⁾ Minimum average optical power at which the BER is less than 1×10^{-12} or lower. Measured with a 2^7-1 NRZ PRBS and ER = 9 dB. Output of multimode fiber 65 μm or 50 μm diameter.

²⁾ An increase in optical power above the specified level will cause the SIGNAL DETECT output to switch from a Low state to a High state.

³⁾ A decrease in optical power below the specified level will cause the SIGNAL DETECT to change from a High state to a Low state.

⁴⁾ DC/DC, AC/DC for data. DC/DC, AC/DC, AC/AC PECL for SD. PECL compatible. Load is 50 Ω into $V_{CC}-2$ V for data, 500 Ω to V_{EE} for Signal Detect. Measured under DC conditions. For dynamic measurements a tolerance of 50 mV should be added. $V_{CC} = 3.3$ V/5 V. $T_{AMB} = 25^\circ\text{C}$.

⁵⁾ Max. output current
 high: -0.4 mA (drive current)
 low: +2.0 mA (sink current)

⁶⁾ AC/AC for data. Load 50 Ω to GND or 100 Ω differential. For dynamic measurement a tolerance of 50 mV should be added.

Eye Safety

This laser based single mode transceiver is a Class 1 product. It complies with IEC 60825-1 and FDA 21 CFR 1040.10 and 1040.11.

To meet laser safety requirements the transceiver shall be operated within the Absolute Maximum Ratings.

Attention: All adjustments have been made at the factory prior to shipment of the devices. No maintenance or alteration to the device is required. Tampering with or modifying the performance of the device will result in voided product warranty.

Note: Failure to adhere to the above restrictions could result in a modification that is considered an act of “manufacturing”, and will require, under law, recertification of the modified product with the U.S. Food and Drug Administration (ref. 21 CFR 1040.10 (i)).

Laser Data

| | |
|---|---------------|
| Wavelength | 850 nm |
| Total output power (as defined by IEC: 7 mm aperture at 1.4 cm distance) | < 675 μ W |
| Total output power (as defined by FDA: 7 mm aperture at 20 cm distance) | < 70 μ W |
| Beam divergence | 12° |

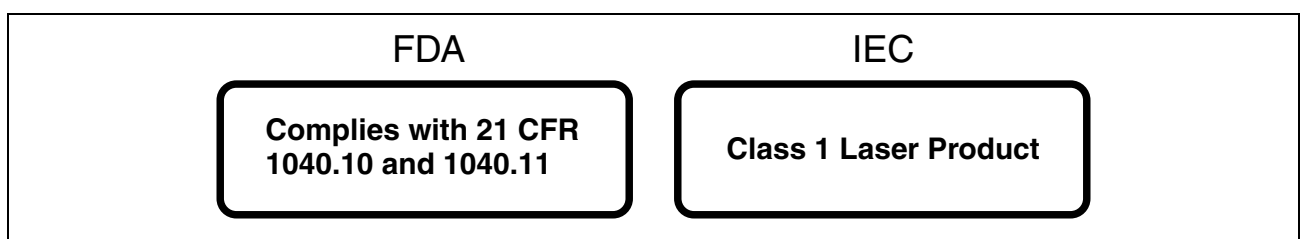

Figure 3 Required Labels

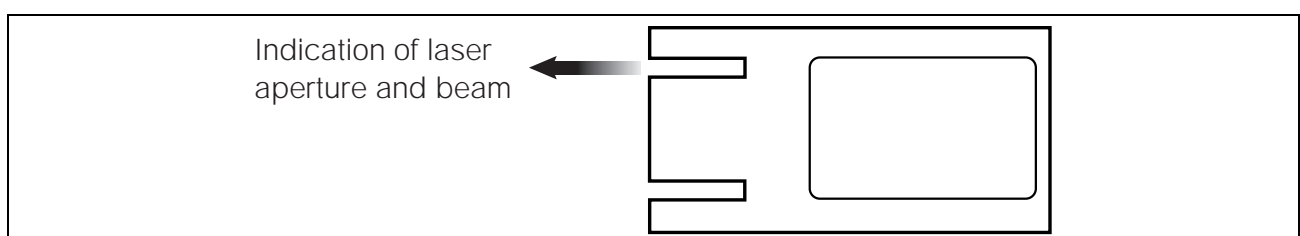

Figure 4 Laser Emission

Application Notes

Gigabit transceivers and matching circuits are high frequency components and shall be terminated as recommended in the application notes for proper EMI performance. Electromagnetic emission may be caused by these components.

To prevent emissions it is recommended that cutouts for the fiber connectors be designed as small as possible.

It is strongly recommended that the Tx plug and the Rx plug be separated with a bar that divides the duplex SC opening.

If shielded parts are employed, they should be in proper contact with the bezel (back plane).

Since the shield is galvanically isolated from signal ground it is strongly recommended to prevent any contact between shield and the circuitry i.e. even any ground connection on the pcb may be harmful to EMI performance.

In cases where EMI performance becomes critical it has proven to be helpful when using SC-plugs with less metal parts inside (as Infineon fibers).

Multimode 850 nm Gigabit Ethernet/Fibre Channel 1x9 Transceiver, DC/DC Version

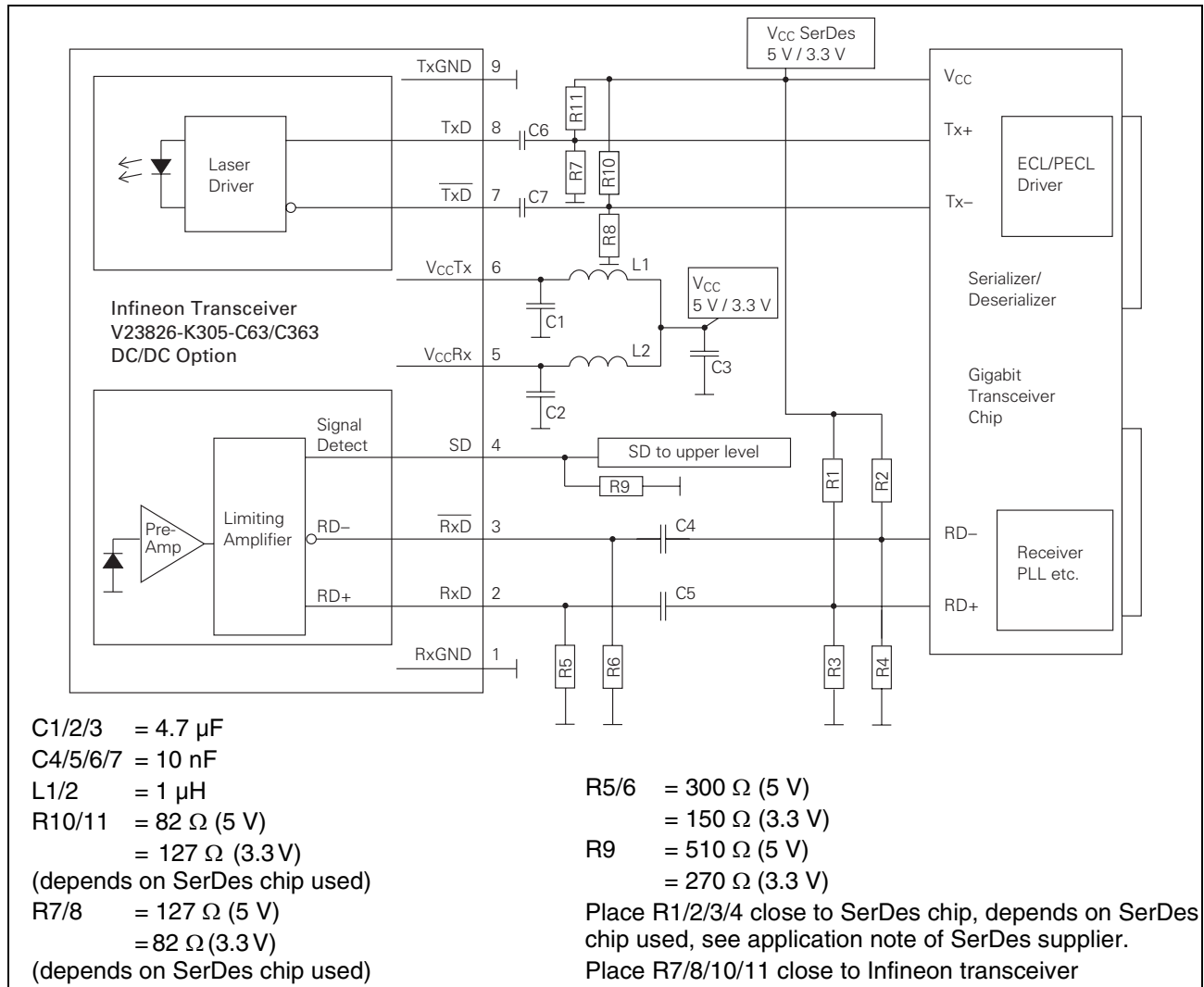

Figure 5

This Application Note assumes Fiber Optic Transceivers using 5 V power supply and SerDes Chips using 3.3 V power supply. It also assumes self biasing at the receiver data inputs (RD+/RD-) of the SerDes chip. Refer to the manufacturer data sheet for other applications. 3.3 V-Transceivers can be directly connected to SerDes-Chips using standard PECL Termination network.

Value of R1 may vary as long as proper 50 Ω termination to V_{EE} or 100 Ω differential is provided. The power supply filtering is required for good EMI performance. Use short tracks from the inductor L1/L2 to the module $V_{CC}Rx/V_{CC}Tx$.

The transceiver contains an automatic shutdown circuit. Reset is only possible if the power is turned off, and then on again. ($V_{CC}Tx$ switched below V_{TH}).

Application Board available on request.

Multimode 850 nm Gigabit Ethernet/Fibre Channel 1x9 Transceiver, AC/DC Version

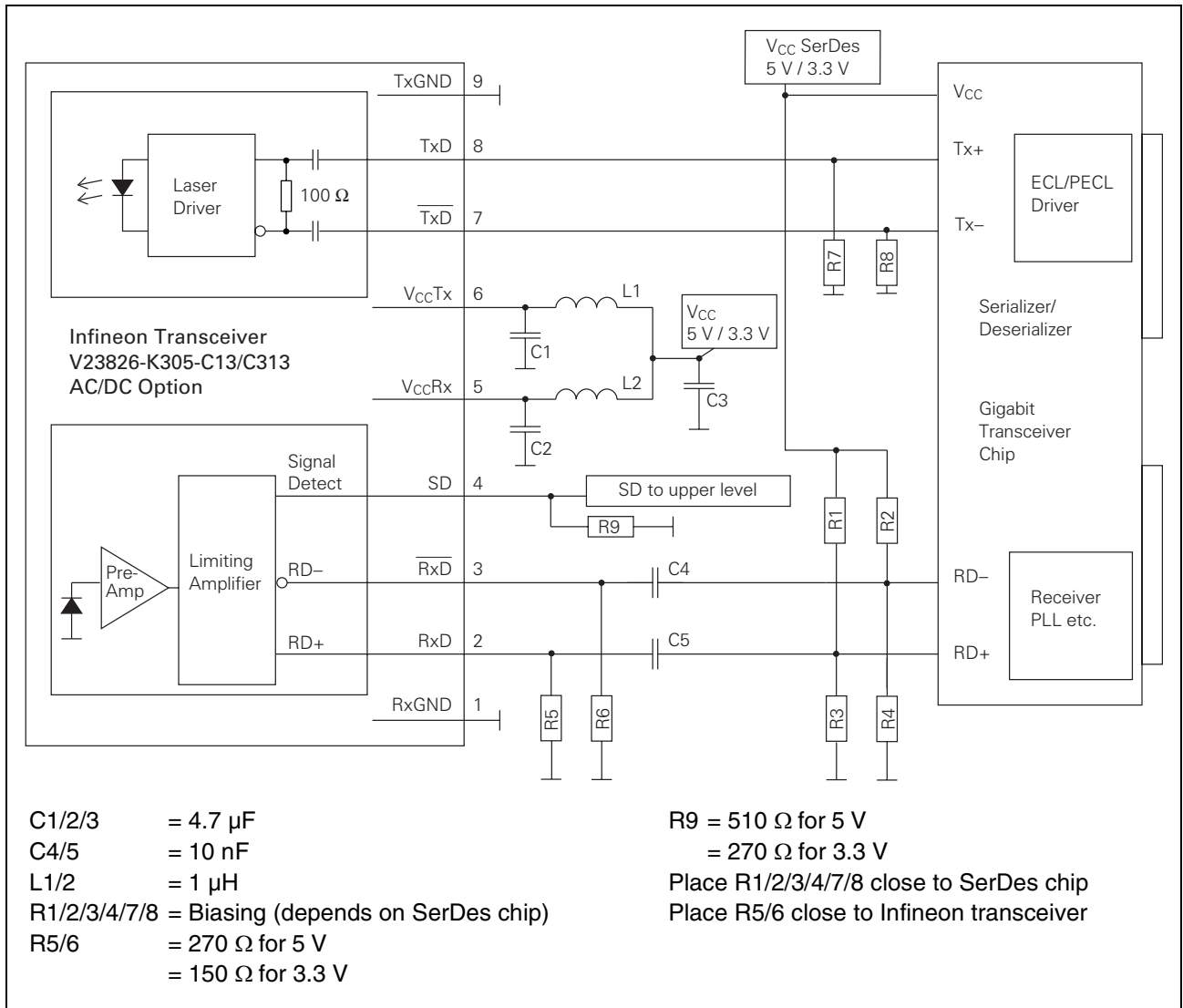
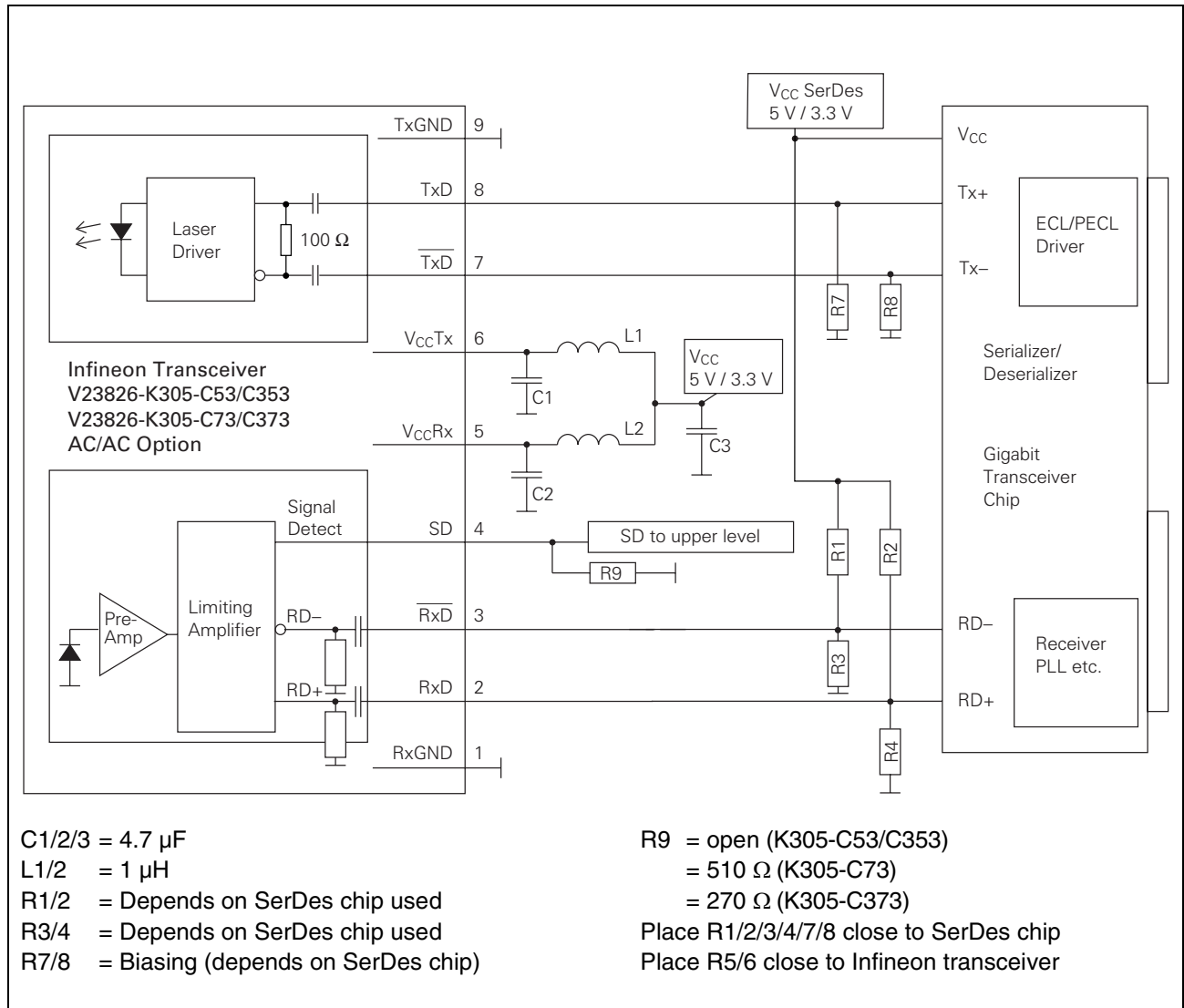

Figure 6

Values of R1/2/3/4 may vary as long as proper 50 Ω termination to V_{EE} or 100 Ω differential is provided. The power supply filtering is required for good EMI performance. Use short tracks from the inductor L1/L2 to the module $V_{CC}Rx/V_{CC}Tx$.

The transceiver contains an automatic shutdown circuit. Reset is only possible if the power is turned off, and then on again. ($V_{CC}Tx$ switched below V_{TH}).

Application Board available on request.

Multimode 850 nm Gigabit Ethernet/Fibre Channel 1x9 Transceiver, AC/AC TTL and AC/AC PECL Versions

Figure 7

Values of R1/2/3/4 may vary as long as proper 50 Ω termination to V_{EE} or 100 Ω differential is provided. The power supply filtering is required for good EMI performance. Use short tracks from the inductor L1/L2 to the module $V_{CC}Rx/V_{CC}Tx$.

The transceiver contains an automatic shutdown circuit. Reset is only possible if the power is turned off, and then on again. ($V_{CC}Tx$ switched below V_{TH}).

Application Board available on request.

Shield Options

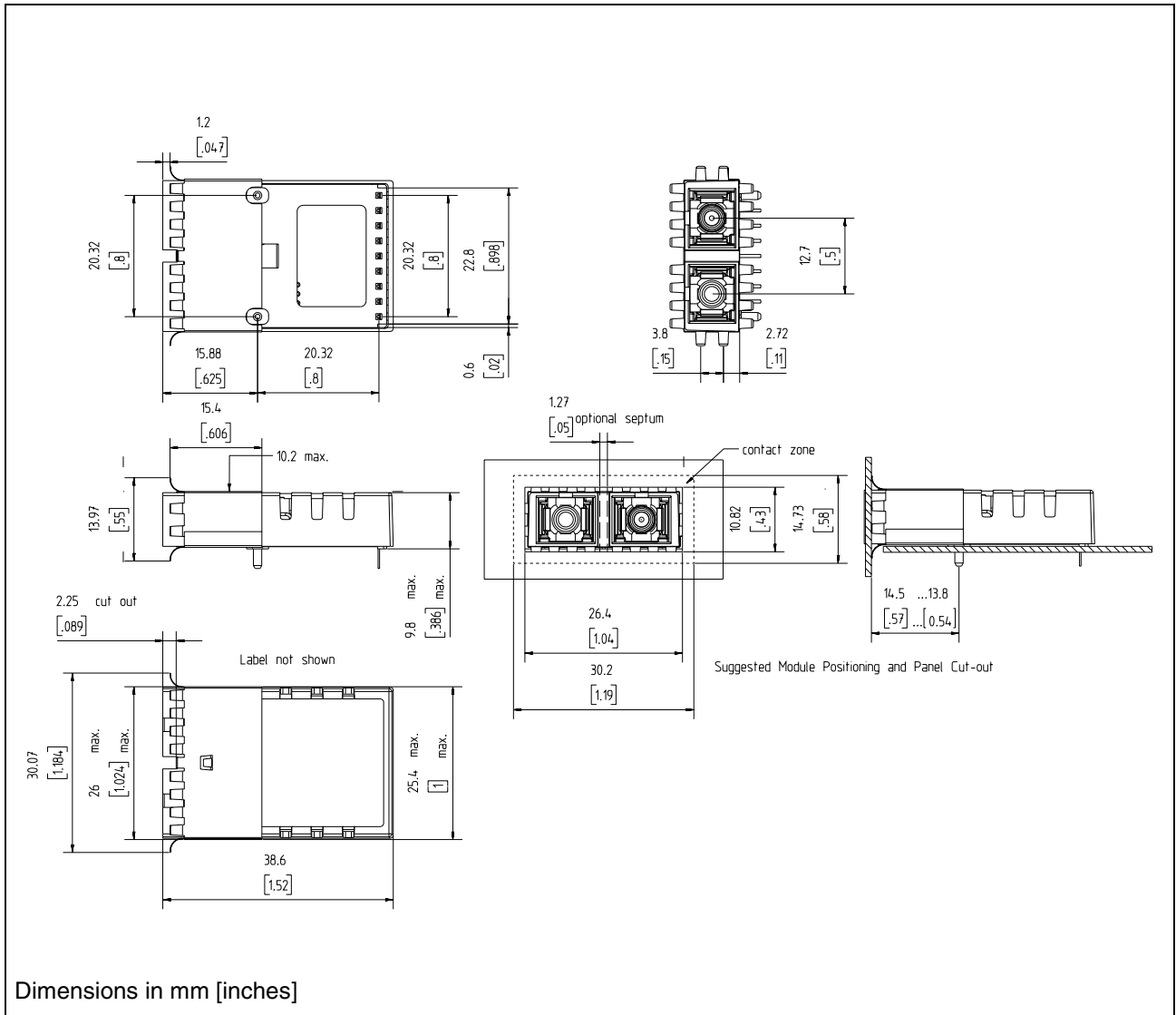

Figure 8 Shield with Forward Springs, -C3

Shield Options

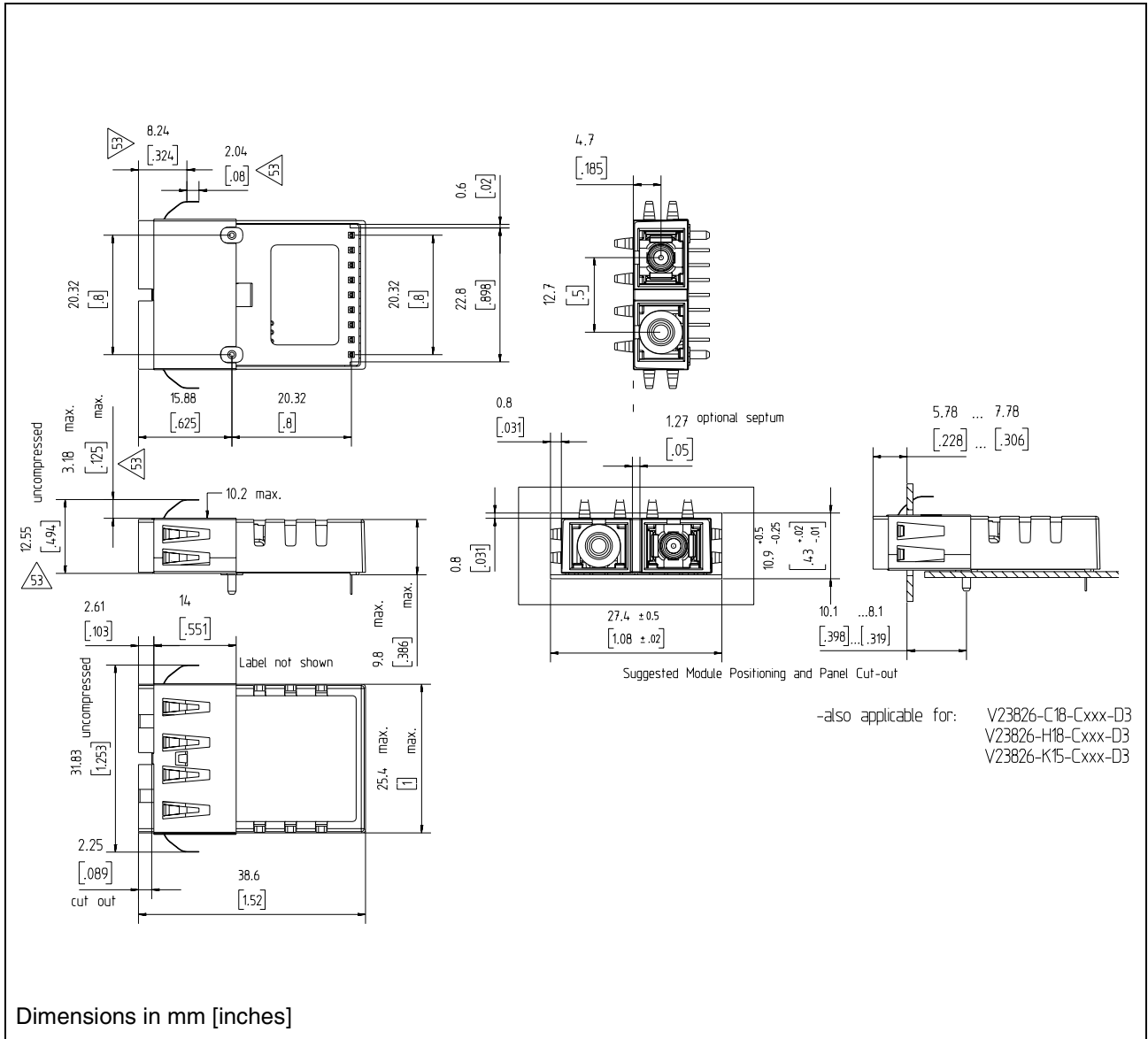

Figure 9 Shield with Backward Springs, -D3

Package Outlines

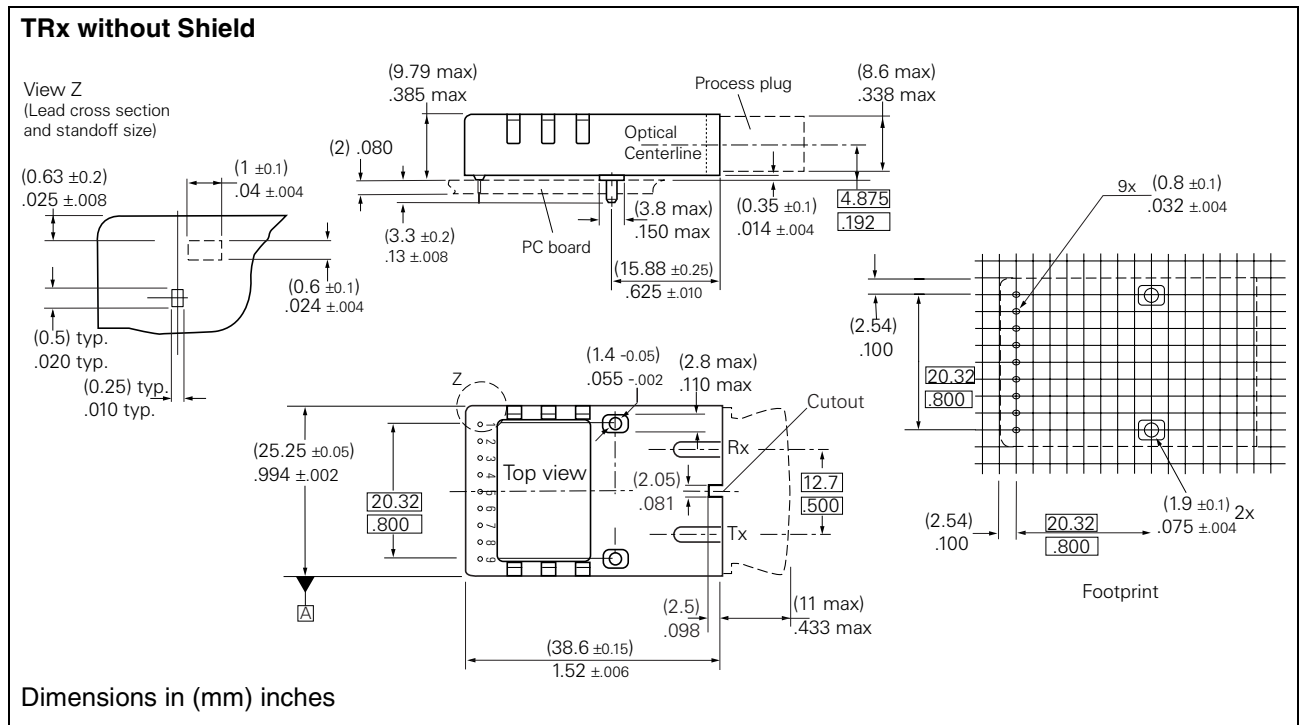

Figure 10

Previous Version:

| Page | Subjects (major changes since last revision) |
|-------------|---|
| | Document's layout has been changed: 2002-Aug. |

For questions on technology, delivery and prices please contact the Infineon Technologies Offices in Germany or the Infineon Technologies Companies and Representatives worldwide: see our webpage at <http://www.infineon.com>.

Edition 2000-12-19

**Published by Infineon Technologies AG,
St.-Martin-Strasse 53,
D-81541 München, Germany**

**© Infineon Technologies AG 2002.
All Rights Reserved.**

Attention please!

The information herein is given to describe certain components and shall not be considered as warranted characteristics.

Terms of delivery and rights to technical change reserved.

We hereby disclaim any and all warranties, including but not limited to warranties of non-infringement, regarding circuits, descriptions and charts stated herein.

Infineon Technologies is an approved CECC manufacturer.

Information

For further information on technology, delivery terms and conditions and prices please contact your nearest Infineon Technologies Office in Germany or our Infineon Technologies Representatives worldwide.

Warnings

Due to technical requirements components may contain dangerous substances. For information on the types in question please contact your nearest Infineon Technologies Office.

Infineon Technologies Components may only be used in life-support devices or systems with the express written approval of Infineon Technologies, if a failure of such components can reasonably be expected to cause the failure of that life-support device or system, or to affect the safety or effectiveness of that device or system. Life-support devices or systems are intended to be implanted in the human body, or to support and/or maintain and sustain and/or protect human life. If they fail, it is reasonable to assume that the health of the user or other persons may be endangered.